

**A Technology Development Plan to Enable a Europa Subsurface Probe
Mission Concept Based on the Vertical Entry Robot for Navigating Europa
(VERNE)**

Samuel Rapoport, Dr. Christopher E. Carr, Dr. Glenn Lightsey¹

May 1, 2021

¹This report was created under Georgia Tech's Vertical Entry Robot for Navigating Europa (VERNE) project led by Dr. Britney Schmidt, and supported by existing work done by Frances Bryson, Chase Chivers, Nathan Daniel, Justin Lawrence, Sara Pierson, Amoree Hodges, Bridget Wiley, Ashley Hanna, Elizabeth Spiers, Taylor Plattner, Matt Meister, Andrew Mullen, Daniel J G Dichek, Justin Burnett, E. Glenn Lightsey, Kynan Hughson, Yashvardhan Tomar, Mohamed Nassif, Philip Szot, Walter King, Madhukarthik Mohanalingam, Ryan Ogilvie, Jacob Buffo, Jeff Bowman, Catherine Walker, Sarah Purkey, Anthony Spears, Christopher E. Carr, and the rest of the VERNE Team.

Executive Summary

Jupiter's moon Europa, with internal energy from tidal heating and a global subsurface saltwater ocean under a thick ice shell, presents incredible promise to the planetary science community in the search for life and in our understanding of ocean worlds. Europa Clipper and a Europa Lander would return valuable information on Europa's environment, but the greatest scientific returns require going beyond Europa's surface and accessing the ocean underneath. Penetrating Europa's thick ice shell is a difficult technical challenge that is beyond the scope of existing planetary science missions, thus a roadmap of how to get from today's technology to a successful Europa subsurface mission is required. Early and continuous investment must be made to close these Significant Technology Gaps if we wish to realize a Europa subsurface mission in the next two decades.

This report identifies Significant Technology Gaps for a Europa subsurface mission, giving context around each technology as well as its application to Georgia Tech's Vertical Entry Robot for Navigating Europa (VERNE) vehicle. Technology needs, identifying where each technology must advance, are explored and compared to the closest existing applications of the technology, including the state of the art and current work in each field. Next steps for each technology, based on the gap between the technology needs and the current work being done, are then recommended. Topics explored include drilling technology, power and thermal systems, sample handling, guidance navigation & control, and structures. This document can additionally be used as a non-exhaustive literature review of these technologies limited to the scope of their application to a Europa subsurface mission. If NASA invests in these critical technologies early and consistently, a Europa melt probe could be selected as early as the decade 2033-2042.

Table of Contents

I.	Introduction	4
I.A.	Report Background.....	4
I.B.	VERNE Mission Concept	4
I.C.	Subsystem Significant Technology Gap Overview	6
II.	Structures Technology Gaps	10
II.A.	Descent-Arresting and Anchoring System in Ice	10
II.B.	Robust Autonomous Tether Management System for Profiling European Water Environment.....	12
II.C.	Passive Unspooling of Tether in European Environment.....	15
II.D.	Lightweight, Corrosive-Resistant, Watertight Exterior Material Capable of Withstanding High Pressure	19
III.	Communication and Data Handling Technology Gaps	21
III.A.	Compact Transmitter of Simple Acoustic Signals through Cryogenic Ice.....	21
III.B.	Higher Areal-Density Radiation-Hardened Memory Storage	24
IV.	Guidance Navigation, Control and Drilling System Technology Gaps	27
IV.A.	Anti-Torque and Roll Stabilization	27
IV.A.1.	Durable Leaf Springs Capable of Sustaining High Loads at Low Temperatures.....	28
IV.A.2.	Anti-Torque Skates Capable of Handling Ice Chips and Slush	29
IV.A.3.	Counter-Rotating Ice Drill.....	30
IV.B.	Mechanical Drill System	32
IV.B.1.	Auger-like Chip Transport on the Drill.....	32
IV.C.	Side-Mounted Forward-Sensing Systems.....	34
IV.C.1.	Long-Range Wide-Angle Sonar	36
IV.C.2.	Compact Radar Capable of Identifying Close Distance Objects	36
V.	Electrical Power System Technology Gaps	38
V.A.	Compact Finless Radioisotope Thermoelectric Generators (RTGs)	38
V.B.	Low-Temperature Rechargeable Batteries	41
V.C.	Low-Temperature High-Energy-Density Primary Batteries.....	42
VI.	Thermal Management System Technology Gaps	45
VI.A.	Mechanically Pumped Fluid Loop for Heat Transfer to Rotating Drill Head	45
VI.B.	Light-Weight Corrosion-Resistant Thermal Hot Plate	51
VII.	Science and Sample Handling System Technology Gaps	54
VIII.	Conclusion	58
IX.	References	59
X.	Appendix	63

I. Introduction

I.A. Report Background

This report was developed as part of the Vertical Entry Robot for Navigating Europa (VERNE) project in collaboration between Georgia Tech’s Planetary Habitability and Technology Lab and the Space Systems Design Lab. VERNE is funded by NASA’s Scientific Exploration Subsurface Access Mechanism for Europa (SESAME) program for a two-year period from May 2019 to May 2021.

The goal of this report is to: (1) identify Significant Technology Gaps between the technology needed for a Europa melt probe mission and its current state, and (2) outline the current work and next steps to catalyze the maturation of these critical technologies.

I.B. VERNE Mission Concept

The following is a summary of the VERNE spacecraft shown in Figure 1 and concept of operations excerpted from the paper “Vertical Entry Robot for Navigating Europa (VERNE): An ice- and ocean-profiling thermomechanical subsurface mission to search for life on Europa” (Schmidt et al 2021):

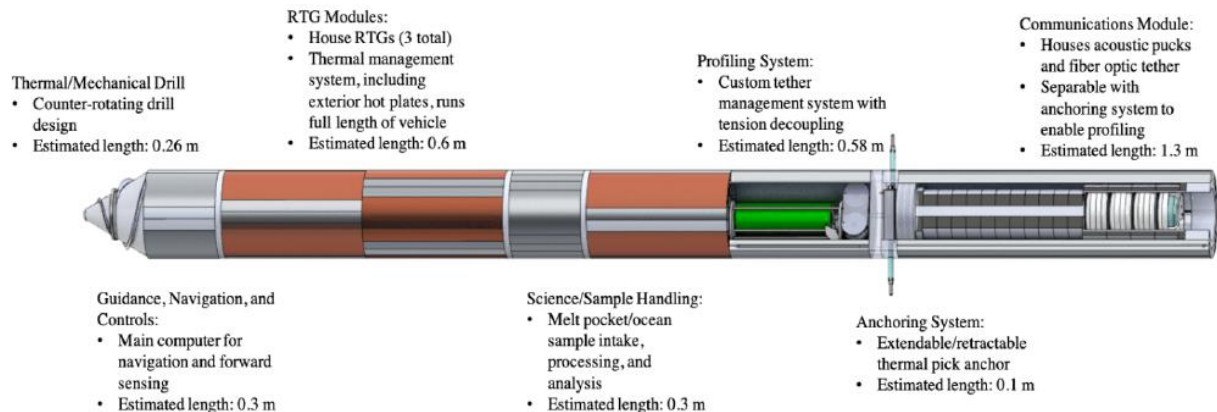

Figure 1. The VERNE spacecraft consists of a forward thermomechanical drill, three Radioisotope Thermoelectric Generators, a science bay with inlets for sample handling, a profiling tether and anchor system, and a rear tether enclosing deployable acoustic pucks (from Schmidt et al 2021).

The VERNE spacecraft consists of a monolithic body 35 cm in diameter and 4.7 meters in length, with a mechanical drill module at the front of the vehicle, three finless Radioisotope Thermoelectric Generators (RTGs), a science bay, and rear module housing communications and the high bandwidth deployable tether with integrated backup acoustic communications pucks (Figure 1). The landing vehicle is outside the scope of this study, we assume the spacecraft to be delivered to the surface and placed in the vertical position prior to the start of operations. We designed the spacecraft using high Technology Readiness Level (TRL) components, for example choosing the MMRTG as the power source in order to reduce mission risk and to achieve a closed design that could be selected in the next decade independent of technical developments in major subsystems, outside of the lander.

While fission reactors or next generation RTGs may be developed for flight in the future, the historical challenges for developing and flight qualifying these systems place additional programmatic risk that can be avoided by choosing the MMRTG. Stepwise improvements in the availability of streamlined RTG pucks or other form factors to save mass and improve power distribution within the vehicle would represent more feasible steps in the coming decade. As designed, the system has an approximate dry mass of 480 kg, inclusive of all contained subsystems, and with an assumed payload mass of 43 kg derived from the SSSLOW study (Schmidt et al 2021).

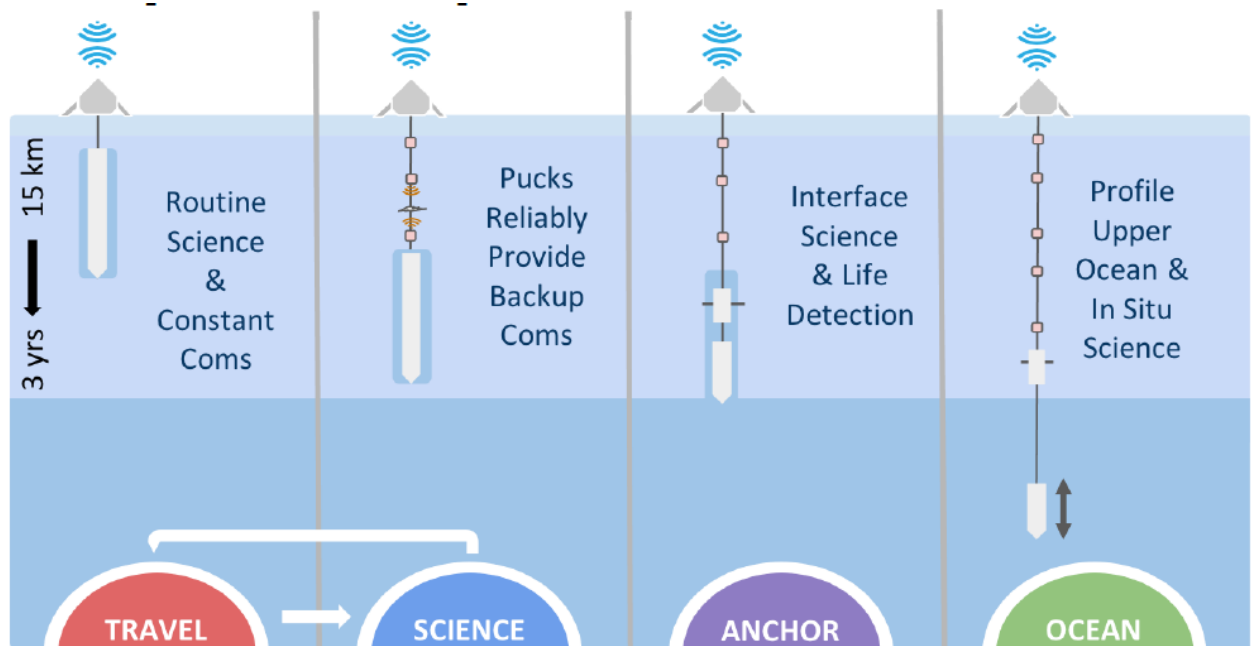

Figure 2. A summary of the VERNE concept of operations. Over three years, VERNE will travel through 15 km of ice and routinely conduct science investigations within the ice shell. Operations at the interface are driven by life detection goals, and ocean operations provide environmental context and the first chance to sample ocean composition and dynamics (from Schmidt et al 2021).

The concept of operations, as seen in Figure 2, would begin with penetration of the cryogenic upper ice shell via mechanical drilling, where the ice is too cold to melt into a liquid melt pocket at European near-surface temperatures. Once deep enough into the ice to begin forming a melt pocket from the vehicle's RTG heat, scientific sampling of the meltwater would occur at a minimum of every kilometer in the ice shell to characterize the ice environment and search for traces of life. As the vehicle descends, a fiber optic tether connected to the surface lander will be unspooled from the vehicle, with acoustic transponders additionally deployed regularly as a backup communications system. Upon approaching the ice-ocean interface, the rear section of the vehicle containing the communication system will separate from the main body of the vehicle and anchor into the ice using thermal pucks, while remaining connected to the main body by a reinforced tether. The rear section would act as an anchor as the main body of the vehicle would vertically profile the water body to a depth of at least 100 m, characterizing the interface and ocean environment for at least one month until end of mission.

I.C. Subsystem Significant Technology Gap Overview

Table I provides a summary of all the Significant Technology Gaps (STGs) identified in this report. For each technology gap, a brief summary of the technology needs of a Europa subsurface mission, relevant work being done developing this technology, and suggested next steps to develop this technology are provided. The remainder of the paper investigates each of these significant technology gaps in detail sorted by subsystem: structures, command and data handling, drilling and guidance navigation & control, electrical power, thermal management, and science and sample handling. While this document focuses on a VERNE-style mission, these STGs are applicable for a wide swath of melt probe missions.

Table I. Subsystem Significant Technology Gap Overview

Significant Technology Gap (STG)	Technology Needs	Current Work	Next Steps
Structures Technology Gaps			
II.A. Descent-Arresting and Anchoring System in Ice	<ul style="list-style-type: none"> Stop descent of vehicle Withstand load of at least 1300 N Deploy into ice in reasonable time Be retractable, redeployable, and secure hold in slush and convective ice Minimize mass and power consumption 	<ul style="list-style-type: none"> “Anchoring thermal drills for icy moon stability and mobility” (Halperin et al 2020) Georgia Tech’s VERNE heated/thermal deployable picks for Europa probe anchoring 	<ul style="list-style-type: none"> Continue Georgia Tech’s benchtop testing of thermal picks for Europa melt probe application Test in Europa-relevant environments and the field
II.B. Robust Autonomous Tether Management System for Profiling European Water Environment	<ul style="list-style-type: none"> Absorb shocks to the vehicle and manage wide range of loads Maintain constant tension to the spool Operate autonomously in a marine environment Prevent excessive damage, wear, and bending to tether 	<ul style="list-style-type: none"> Coastal Autonomous Profiling and Boundary Layer (CAPABLE) System (Barnard et al 2010) Axel rappelling rover (Brown et al 2018) Georgia Tech’s VERNE Tether Management System 	<ul style="list-style-type: none"> Test in marine environment similar to Europa’s Package system to mass and volume conducive to a Europa melt probe mission
II.C. Passive Unspooling of Tether in European Environment	<ul style="list-style-type: none"> Passively unspool 15+ km of tether Prevent tangling or damage to tether Minimize total volume 	<ul style="list-style-type: none"> Nereid Under Ice Remotely Operated Vehicle (Jakuba et al 2018) Nereid Under Ice micro-tether (Bowen 2009) Tether Management Systems for Remotely Operated Vehicles (Christ et al 2014) 	<ul style="list-style-type: none"> Miniaturize fiber optic passive spooling systems Test passively unspool armored fiber optic tether in ice environment for multiple kilometers
II.D. Lightweight, Corrosive-Resistant, Watertight Exterior Material Capable of Withstanding High Pressure	<ul style="list-style-type: none"> Withstand corrosive saline environment for multiple years Sustain temperatures from 90 K to 273 K 	<ul style="list-style-type: none"> Compass Tunnelbot Report (Oleson et al 2019) Argo oceanography probes using Teledyne Marine’s APEX Current Profiling Float (Riser et al 2018) Icefin Under-Ice Vehicle (Meister et al 2018) Composite honeycomb structure with aluminum 	<ul style="list-style-type: none"> Test corrosive responses of materials to Europa conditions Field-test materials in Europa-like conditions over long time-scales Develop composite material technology for spacecraft applications Continue developing novel lightweight high-strength materials

		<p>face sheeting for Mars rovers (Atams et al 2007)</p> <ul style="list-style-type: none"> Plasma electrolytic oxidation corrosion resistant coating for aluminum (Shrestha et al 2010) 	
Communication and Data Handling Technology Gaps			
III.A. Compact Transmitter of Simple Acoustic Signals through Cryogenic Ice	<ul style="list-style-type: none"> Contain onboard power Minimize system volume, mass, and power consumption Survive and communicate in temperatures from 90 K to 273 K Communicate over hundreds to thousands of meters in ice 	<ul style="list-style-type: none"> South Pole Acoustic Test Setup (Abdou et al 2012) Characterization of attenuation of soundwaves through glacier ice (Meyer et al 2019) Feasibility of wireless acoustic transmitters in the Greenland Ice-Sheet (Lishman et al 2013) IceMole Autonomous Pinger Units (Weinstock et al 2020) 	<ul style="list-style-type: none"> Demonstrate data transmission through ice Miniaturize self-contained acoustic transmitters with onboard power Demonstrate acoustic data transmission vertically through Europa-analogous ice Demonstrate modulated data transmission through ice
III.B. Higher Areal-Density Radiation-Hardened Memory Storage	<ul style="list-style-type: none"> Be radiation hardened Tolerate low temperatures Fit in minimal volume Reliably store tens of gigabytes 	<ul style="list-style-type: none"> JPL's Manx Command and Data Handling System for the Europa Lander (Bolotin et al 2018) High-performance commercial off the shelf space-rated electronics (Pignol 2010) 	<ul style="list-style-type: none"> Continue development of low-temperature, compact, radiation-hardened avionics Reduce areal density of memory storage Increase total storage capacity of radiation-hardened space-rated memory storage systems
GN&C and Drilling System Technology Gaps			
IV.A.1. Durable Leaf Springs Capable of Sustaining High Loads at Low Temperatures	<ul style="list-style-type: none"> Provide counter-torque in variable diameter borehole Operate in 90 K cryogenic ice as well as slush Be durable enough to operate for 3 years without repair 	<ul style="list-style-type: none"> Leaf Spring Anti-Torque Systems used for Ice-Coring Drills (Talalay et al 2014) Eclipse Ice Coring Drill (Scambos 2020) Automotive carbon-fiber leaf springs (Soner et al 2012) 	<ul style="list-style-type: none"> Test leaf springs at cryogenic temperatures and saline environment Design and test leaf springs for operating autonomously for 3+ years
IV.A.2. Anti-Torque Skates Capable of Handling Ice Chips and Slush	<ul style="list-style-type: none"> Avoid freezing and locking in ice 	<ul style="list-style-type: none"> Skate Anti-Torque Systems used for Ice-Coring Drills (Talalay et al 2014) 	<ul style="list-style-type: none"> Test skate-mounted-on-leaf-spring design Demonstrate ice-chip-management capability Investigate embedded thermal resistors in anti-torque system Design and test skates for operating autonomously for 3+ years
IV.A.3. Counter-Rotating Ice Drill	<ul style="list-style-type: none"> Provide equal torques between upper and lower sections Ensure continuous contact with ice for upper and lower sections Prevent particles entering between sections Facilitate continuous chip transport between sections 	<ul style="list-style-type: none"> Small-scale counter-rotating thermomechanical drill for Europa application (Weiss et al 2011) 	<ul style="list-style-type: none"> Test counter-rotating thermomechanical drills further in laboratory setting Scale up to full-sized drills tested in the field, then Europa-like environments

<p>IV.B.1 Auger Like Chip Transport on Drill</p>	<ul style="list-style-type: none"> • Transport ice chips from in front of vehicle to behind • Have high cutting efficiency across different environments • Minimize loss of chips between counter-rotating drill sections 	<ul style="list-style-type: none"> • Ice chip transport for electromechanical augers in polar glacier environments (Hong et al 2014) • Honeybee Robotics' SLUSH drill (Zacney et al 2018) • Small-scale counter-rotating thermomechanical drill for Europa application (Weiss et al 2011) 	<ul style="list-style-type: none"> • Test conical drills with auger-like chip transport in Europa-like conditions including cryogenic and temperate ice as well as salt deposits • Field tests in multiple meters to kilometers of ice
<p>IV.C.1. Long-Range Wide-Angle Sonar</p>	<ul style="list-style-type: none"> • Side- and front-mounted sonar/radar • >100 m range • Minimize volume, power, and blind spot/cone ahead of vehicle 	<ul style="list-style-type: none"> • IceMole Acoustic Reconnaissance System (ARS) (Kowalski et al 2016) • IceMole Autonomous Pinger Unit (APU) (Weinstock et al 2020) 	<ul style="list-style-type: none"> • Test body mounted acoustic transducers • Balance long range with sufficient resolution • Improve medium coupling of acoustic transducers to the ice • Reduce losses due to the water film between the transducer and ice environment.
<p>IV.C.2. Compact Radar Capable of Identifying Close Distance Objects</p>	<ul style="list-style-type: none"> • Side- and front-mounted sonar/radar • >100 m range • Minimize volume, power, and blind spot/cone ahead of vehicle 	<ul style="list-style-type: none"> • VALKYRIE Ice Synthetic Aperture Radar (Pradhan et al 2016) • Autonomous phase-sensitive Radio-Echo Sounder (ApRES) (Bagshaw et al 2018) 	<ul style="list-style-type: none"> • Improve efficiency of low-frequency small antennae • Minimize power, volume, and mass • Develop autonomous system that can operate for years without repair • Develop techniques to eliminate interference from components in front of the sensor

Electrical Power System Technology Gaps

<p>V.A. Compact Finless Radioisotope Thermoelectric Generators (RTGs)</p>	<ul style="list-style-type: none"> • Capture heat from RTGs through an active thermal loop • Minimize diameter and mass • Utilize no radiator fins • Increase electrical conversion efficiency 	<ul style="list-style-type: none"> • "Enhanced Multi-Mission Radioisotope Thermoelectric Generator (eMMRTG) Concept" • "Finless RTG Power System Concept" • "Dynamic Radioisotope Power Systems" • Next-Gen Sectioned Modular RTGs (Zakrajsek et al 2017) 	<ul style="list-style-type: none"> • Develop RTG without fins • Develop SKD thermocouple technology and test module • Begin development of qualification unit for segmented and modular RTGs • Complete prototypes of Dynamic Radioisotope Power Systems
<p>V.B. Low-Temperature Rechargeable Batteries</p>	<ul style="list-style-type: none"> • Withstand temperatures in the range of -60 °C to -80 °C • Maximize energy density 	<ul style="list-style-type: none"> • Mars Insight Lander battery (M. C. Smart et al 2019) • Low-temperature rechargeable lithium-ion batteries (Surampudi 2017) 	<ul style="list-style-type: none"> • Develop low-temperature electrolytes that can conduct ionically in a film on the electrode • Using solvents with low viscosity and melting point • Enable batteries with specific energies 150-200 Wh/kg with an operating range of -60 °C to 30 °C
<p>V.C. Low-Temperature High-Energy-Density Primary Batteries</p>	<ul style="list-style-type: none"> • Operate with -80 °C transmitter internal temperatures • Energy density of at least 800 W-hr/L, ideally 2400 W-hr/L 	<ul style="list-style-type: none"> • Thionyl Chloride (Li-SOCl₂), Lithium-Carbon Monofluoride (Li-CFx), Thionyl Chloride (Li-SOCl₂) (Surampudi 2017) 	<ul style="list-style-type: none"> • Develop alternate electrolytes, salts, and additives • Modified electrode design • Understand effects of radiation exposure to develop methods for planetary protection

Thermal Management System Technology Gaps

<p>VI.A. Mechanically Pumped Fluid Loop for Heat Transfer to Rotating Drill Head</p>	<ul style="list-style-type: none"> • Transfer heat from a nuclear power source to the nose of the vehicle at high efficiency and minimal sidewall loss • Operate continuously for multiple years • Minimize mass, volume, and power consumption 	<ul style="list-style-type: none"> • Mars Science Laboratory Mechanically Pumped Fluid Loop (Bhandari et al 2013) • VALKYRIE probe open meltwater loop (Stone et al 2014) • SPINDLE Closed Fluid Loop (Stoe et al 2018) • IceCube firm heated fluid drill (Benson et al 2014) • Small-scale counter-rotating thermomechanical drill for Europa application (Weiss et al 2011) 	<ul style="list-style-type: none"> • Test a mechanically pumped fluid loop for a Europa melt probe vehicle prototype • Utilize a nuclear or nuclear-representative heat source • Design and test system allowing for transfer of heat by a non-rotating fluid loop to a rotating drill head • Develop small low-power, high-reliability pumps
<p>VI.B. Light-Weight Corrosion-Resistant Thermal Hot Plate</p>	<ul style="list-style-type: none"> • Have a low density and a high strength • Be corrosion resistant for possible years of exposure to saline environments • Conductive to complex fluid channel geometries 	<ul style="list-style-type: none"> • Electron-Beam Additively Manufactured Titanium Structures (Sciaky 2021) 	<ul style="list-style-type: none"> • Demonstrate corrosion resistance in saline environments • Demonstrate additive manufacturing of embedded fluid channels • Explore other lightweight, corrosion-resistant high-strength materials
<p>Science and Sample Handling System Technology Gaps</p>			
<p>VII. Science and Sample Handling System</p>	<ul style="list-style-type: none"> • Tolerate launch, spaceflight, high-pressure liquid environments, and possibly corrosive salts and deposits • Detect low concentrations of biosignatures • Operate highly autonomously • Sample with high resolution in unsteady terrain • Handle dust, debris, salts, and trapped gasses 	<ul style="list-style-type: none"> • Instrument development for Europa missions, field-tested oceanographic science vehicles, life-detection and sampling technologies for icy ocean worlds, and Europa melt probe payload concept (see Lawrence et al 2021 for review) 	<ul style="list-style-type: none"> • Leverage existing expertise across different fields and industries • Increase autonomous capabilities of small volume liquid sample collection • Combine flow through and discrete liquid sampling for small volume systems • Autonomous desalting, depressurizing, and concentration of milliliter and microliter sized systems

II. Structures Technology Gaps

II.A. Descent-Arresting and Anchoring System in Ice

Context:

For a Europa melt probe mission to descend through the ice shell and stop near the ice-ocean interface, a mechanism to prevent the vehicle from sinking into the ocean as well as maintain a connection to the surface is necessary. A high-risk method of doing this is relying solely on a tether to keep the vehicle from sinking or floating away. Alternatively, a buoyancy device attached to a tether could be utilized, but if the tether breaks at a point not in the ice, the vehicle could still lose connection to the surface.

Another method is to have the vehicle separate into two sections, with the rear section anchoring into the ice, connected to the forward section by reinforced tether while it investigates the water body. This way, a break in the tether above the anchor point does not risk loss of vehicle, and the tether connecting the anchor and profiling section of the vehicle can be heavily reinforced without significant mass increase. The anchoring section of the vehicle can be secured by several low-TRL concepts, including a mechanical clamp using friction to grip the sidewall or by picks penetrating mechanically or thermally into the ice.

VERNE Context:

When approaching the ice-ocean interface, the rear anchor module of the VERNE vehicle separates and releases thermal picks laterally into the ice to stop the descent of the vehicle. The anchor module also contains the vehicle's communication system and memory storage, allowing continued transmission of onboard data in the event the main vehicle section is lost. The main section of the vehicle is connected by a reinforced tether that transmits data and power to the anchor module as it profiles the water body.

Thermal picks were chosen for VERNE's design for their retractability and decreased size as compared to mechanical clamps, allowing for operational flexibility. Thermal insertion by pressing heated picks into the ice was found to better maintain the structural integrity of the ice compared to mechanical insertion (Halperin et al 2019).

Technology Needs:

The anchoring system must be able to arrest the descent of the full weight of the vehicle by deploying sufficiently heated picks in an acceptable timeframe and withstand a load of at least 1300 N (derived from a conservative estimate of a 500 kg vehicle with a safety factor of two). The anchoring system must be retractable, redeployable, and able to secure itself in slush and convective ice while minimizing mass and power consumption.

Current Work:

A University of Maryland study on “Anchoring thermal drills for icy moon stability and mobility” tested lateral thermal picks with an intended application for the surface of icy moons, with an emphasis on sublimating cryogenic ice of $-170\text{ }^{\circ}\text{C}$ that would be found on Europa’s surface rather than convective ice near $0\text{ }^{\circ}\text{C}$ that would be found near the ice-ocean interface (Halperin et al 2020). The test setup is shown in Figure 3, and parameters examined included tip shape, insulation of thermal pick, heater power, thermal pick temperature, intervals between pick reinsertion, and pressure exerted by the pick into the ice.

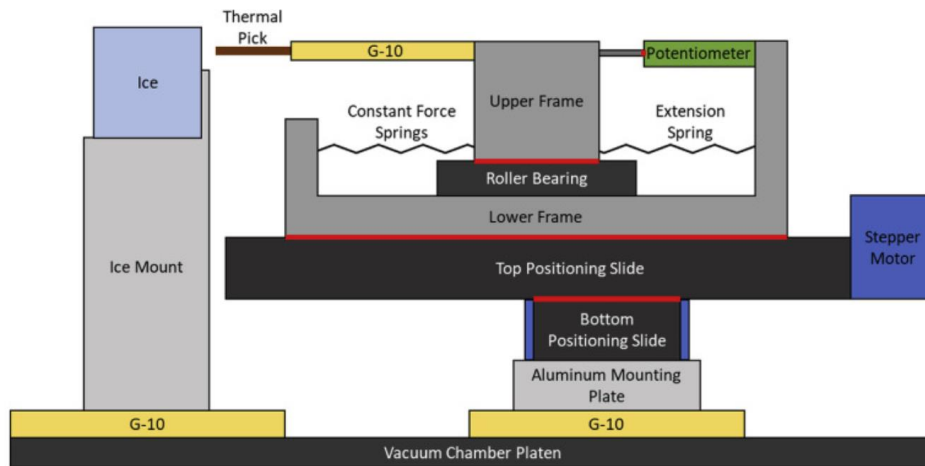

Figure 3. Thermal Pick Test Rig Schematic (from Halperin et al 2020).

A small negative taper (narrowest at base and widest at the tip) of 3.58 degrees was found to prevent the probe from undesirably pulling out from the ice while minimizing the amount of ice that would have to be re-melted when retracting. To more efficiently penetrate the ice and minimize unwanted conductive heat loss to the environment, a duty cycle (retracting from the ice temporarily while the pick reheats) was found to be effective. Ice failure due to thermal stall was minimized at higher pick temperatures (hottest tested was $160\text{ }^{\circ}\text{C}$ due to melting point of epoxy used) and small insertion steps (3mm), with reheating intervals below 20 seconds. Ideal pick conditions and ice failure mechanisms are expected to be different for the tested cryogenic ice of $-170\text{ }^{\circ}\text{C}$ near vacuum, compared to the expected near $0\text{ }^{\circ}\text{C}$ and significant pressures at the ice-ocean interface. Heater cartridges used were from 18-24 V with a power consumption of 16-32 W, and a duty cycle between ice insertions of 5-25%, with the thermal picks successfully holding the 100 N force. Through these experiments, the viability of a thermal pick to maintain ice integrity and hold vehicle loads at a reasonable size and power consumption has been shown (Halperin et al 2020).

The Georgia Tech VERNE team is in the process of testing thermal picks for arresting descent in the conditions expected at Europa’s ice-ocean interface. The functionality of lateral insertion into ice, refreezing, and retraction will be demonstrated first for a linearly actuated benchtop thermal pick similar to Halperin’s tests (Halperin et al 2020), as seen in Figure 4 (a). The scenario of a descending vehicle will then be tested and the thermal picks deployed into ice

blocks as shown in Figure 4 (b), first with a static mass pulling downward, then with the thermal pick platform moving downward at expected speeds with the simulated vehicle weight. Upon demonstration of the descending platform, the test will be repeated with the system surrounded by a liquid water jacket, replicating the water pocket that will surround the vehicle on Europa.

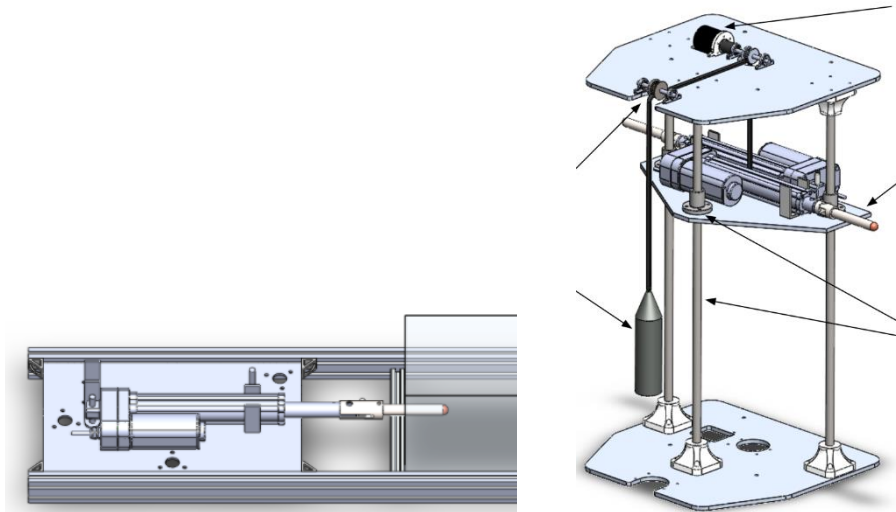

Figure 4. (a) Benchtop Thermal Pick Testing Rig (b) Descending Thermal Pick Testing Rig.

Next Steps:

Georgia Tech's work intends to demonstrate the functionality of a laterally actuated thermal pick in a relevant environment to Europa's ice-ocean interface. Upon its completion, optimal tip shape, tip entry angle, duty cycle, and power vs. time operating point can be determined through further experiments. Testing could then progress from a laboratory setting to the field such as ice shelves, where deployment and anchoring can be demonstrated in a marine ice environment.

II.B. Robust Autonomous Tether Management System for Profiling European Water Environment

Context:

For a Europa melt probe vehicle to fully characterize the subsurface ocean, it must deploy a system capable of traversing it. The melt probe vehicle can serve as an autonomous underwater vehicle (AUV) itself, station into the ice and deploy an AUV unconnected to the main vehicle, or it can separate into a section that anchors into the ice and a section that profiles the ocean, connected by tether. An anchor and tether system represents the lowest risk by anchoring the vehicle and not relying on a separate system, and lowest complexity by not requiring additional vehicles or autonomous ocean navigation.

A tether must connect the anchored section of the vehicle to the ocean-profiling section, serving the structural purpose of mooring the profiler and keep it from floating away, as well as possibly providing communications and/or electricity between the profiler and anchored section. A Tether Management System (TMS) is needed to wind and unwind the tether as the vehicle profiles up and down in the water column. The system must minimize shocks experienced by the tether and sustain a range of loads on the tether from possibly varying ocean currents while maintaining constant tension to the spool for consistent winding and unwinding.

VERNE Context:

The rear section of the VERNE vehicle anchors into the ice and attaches to the ocean profiling section via a tether. The tether prevents the profiler from drifting away as well as exchanges both communication signal and electrical power between the profiler and anchor sections. VERNE's Tether Management System contains a tension decoupling mechanism to prevent the variable tension experienced on the tether from transferring to the spooling system. The spooling system operates under constant tension, allowing the motorized spool to more smoothly wind and unwind tether, assisted by a level wind to prevent tangling and knotting. The tether is designed to be ~200 m long, allowing 100 m of profiling in the water body and enough tether to extend from the anchor to the ice-ocean interface.

Technology Needs:

A Tether Management System is needed to absorb shocks to the vehicle and maintain a constant tension to the spool while managing a wide range of loads experienced by the vehicle. The TMS needs to operate autonomously in the ice shell and marine environment and prevent excessive damage, wear, or bending to the tether.

Current Work:

The Coastal Autonomous Profiling and Boundary Layer (CAPABLE) System is an autonomous vehicle that measures coastal ocean environments in high resolution by vertically profiling the water, attaching by a tether to the ocean floor (Barnard et al 2010). The vehicle demonstrates an onboard winch system that can autonomously spool and unspool 250 m of tether and operate for a period of three months. Different from a Europa melt probe mission, the tether transmits neither communication nor power, CAPABLE instead communicates by RF signal and relies on onboard power. The vehicle is anchored at the bottom of the ocean rather than the top and is positively buoyant, requiring power when going downwards towards the underwater dock. The tether sustains significantly less tension than a Europa melt probe would, and thus doesn't use a tension decoupling system, but CAPABLE does successfully demonstrate an onboard marine winch system for a vertical profiler.

Axel is a field-tested rover designed to rappel steep terrains on rocky planets that traditional rovers cannot traverse (Brown et al 2018). A tether management system like one

needed for a Europa melt probe mission has been tested for Axel in a laboratory setting, whose diagram can be seen in Figure 5.

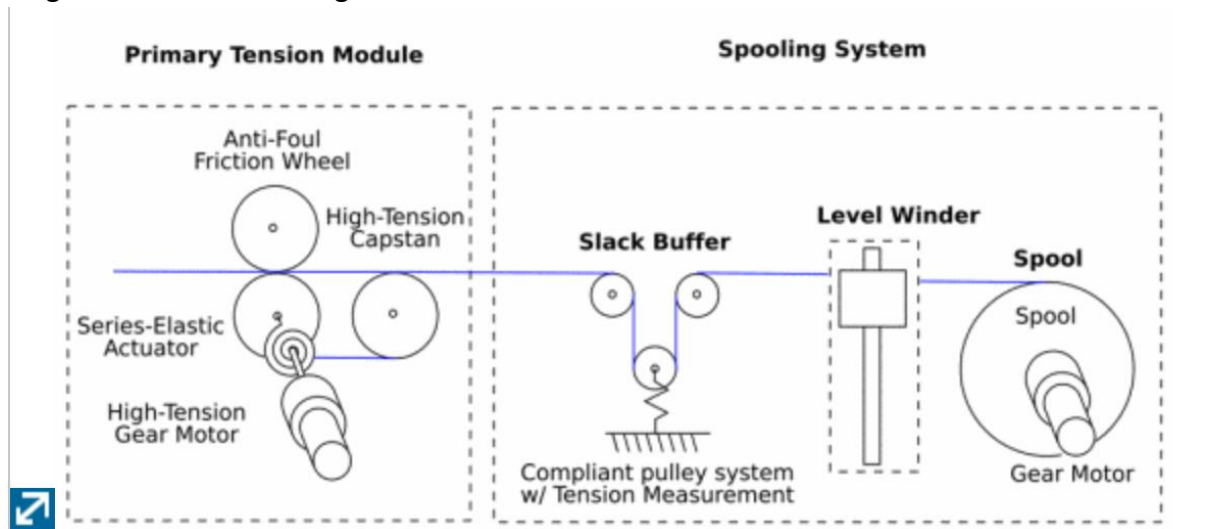

Figure 5. Axel Tether Management System Diagram (from Brown et al 2018).

Axel's tether, like a possible Europa melt probe design, holds the vehicle's weight as well as transmits power and communications. Additionally, Axel uses a tension decoupling system to separate the tension of the deployed tether from the internal untensioned spool, utilizing a series-elastic actuator acting as a rotational spring to absorb shocks. A slack buffer decouples the motion of the spool from the motion of the tension decoupler, while also measuring the tension on the line. The spool is wound and unwound by a motor with a level winder to prevent tangles and knots in the tether. A tether response the authors noted that they anticipate testing further is the increase in stiffness the tether experiences when under strain. This could cause issues in the field due to changes in the tether's minimum allowed bend radius if under stress, increasing the need for a tension decoupling system within a TMS. Axel's tether management system, when deployed in the field, will demonstrate successful usage of a tension decoupling system and level wind on an exploratory vehicle's onboard winch system in a terrestrial setting.

Georgia Tech's VERNE project is developing a laboratory prototype of a Tether Management System (TMS) designed for a Europa melt probe, seen in Figure 6. The tension experienced by the system's weight is decoupled by the upper tension decoupling system. The constant-tensioned tether is then wound and unwound around its spool using a level wind. Upon completion, the project will demonstrate a benchtop TMS that can autonomously spool and unspool multiple wraps of tether.



Figure 6. VERNE Tether Management System (a) CAD Model (b) Prototype (F. Bryson).

Next Steps:

A Tether Management System still needs to be developed and field-tested in a marine environment similar to Europa's, with a mass and volume that would be conducive to a European melt probe vehicle's diameter. The Axel program's implementation of a TMS in a terrestrial above-ground environment, as well as Georgia Tech's VERNE prototyping of a TMS for a Europa melt probe both promise increases in technology readiness. Upon successful lab testing of a marine TMS using a tension decoupling system, field-testing in a marine location such as Antarctica would provide valuable information on designing a European TMS with confidence.

II.C. Passive Unspooling of Tether in European Environment

Context:

The need for a vehicle to communicate through Europa's thick ice shell with a surface system poses a significant challenge. A fiber optic tether is a low-mass, extremely high throughput option that would allow large amounts of data exchanged between the vehicle and the surface. Acoustic or RF repeaters are also considered in designs such as Tunnelbot as backups in case the fiber optic tether is severed (Oleson et al 2019).

The fiber optic tether would need to be on the Europa melt probe vehicle, as the ice will refreeze behind the vehicle, eliminating a spool managed from the surface. To fit onboard the vehicle, the 15-30 km of tether needs to respect a minimum bend radius while minimizing

overall diameter. A fiber optic tether would primarily function for communication, rather than structural loading or transmitting power in order to simplify operations and save mass, and the tether may not require to being re-wound, though this may vary by mission. Nonetheless, passive unspooling of the tether as the vehicle descends would reduce complexity and eliminate the need for a spool motor.

VERNE Context:

The VERNE vehicle will passively deploy a fiber optic tether out of the rear of the vehicle. The tether in the brittle upper ice shell may be reinforced, while the tether in the lower ice shell can be bare fiber optic, as ice shear will not be an issue in the warmer convective ice. VERNE will also have acoustic repeater pucks placed each kilometer in the ice shell as a secondary communication system in case the tether breaks.

Technology Needs:

A method of passively unspooling fiber optic tether for significant lengths (15-30 km), while preventing tangling or damaging of the tether and minimizing total volume is needed.

Current Work:

The Nereid Under Ice (NUI) is a Remotely Operated Vehicle used in exploring under-ice ocean environments in the arctic (Jakuba et al 2018). To allow unrestricted movement under shifting sea ice in the open ocean, while stationed from an icebreaker ship with limited mobility, a long, thin unarmored expendable fiber optic tether, dubbed a micro-tether, is used to communicate with the vehicle. The micro-tether is 250 microns in diameter and has been tested up to a length of 5 km, with a theoretical maximum of 10-20 km, able to bear a load of up to 2 N before breaking. The micro-tether is fit into two small canisters, one near the vehicle and one near the ship, and the tether is free to unspool from either end, as seen In Figure 7.

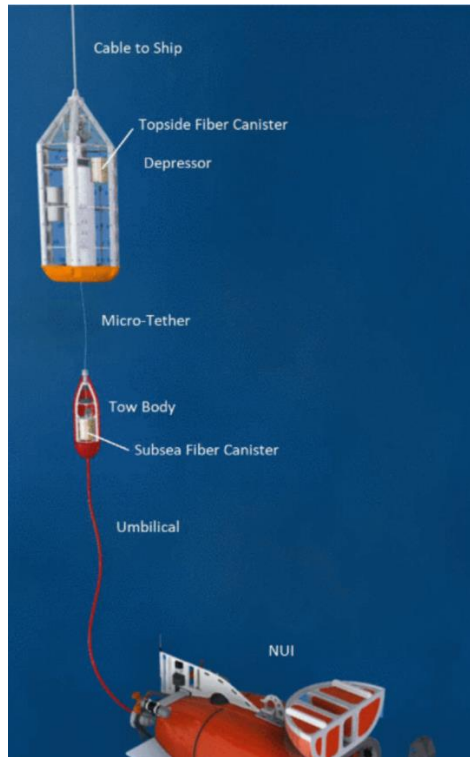

Figure 7. Nereid Under Ice Micro-tether Deployment (from Jakuba et al 2018).

The micro-tether patent describes the cable payout device that can be seen in Figure 8 (Bowen 2009). The micro-tether is stored in a spool in the bottom canister (660), and under tension is pulled vertically off the spool, wraps around the capstan drum (658) coupled to a tension assembly (654) then upward between the top cleats (652) forming a brake system. This brake system can either operate passively with constant torque through a mechanical spring or actively through an electrical system.

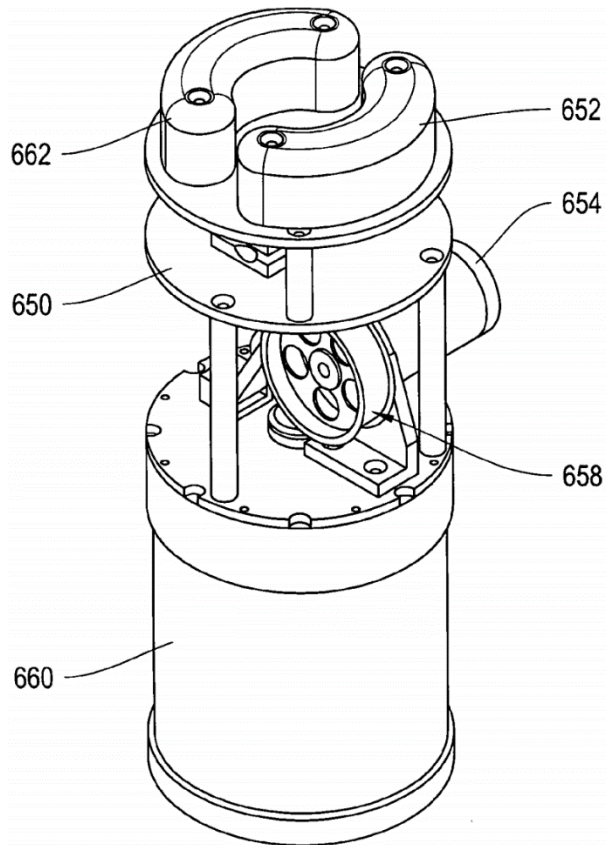
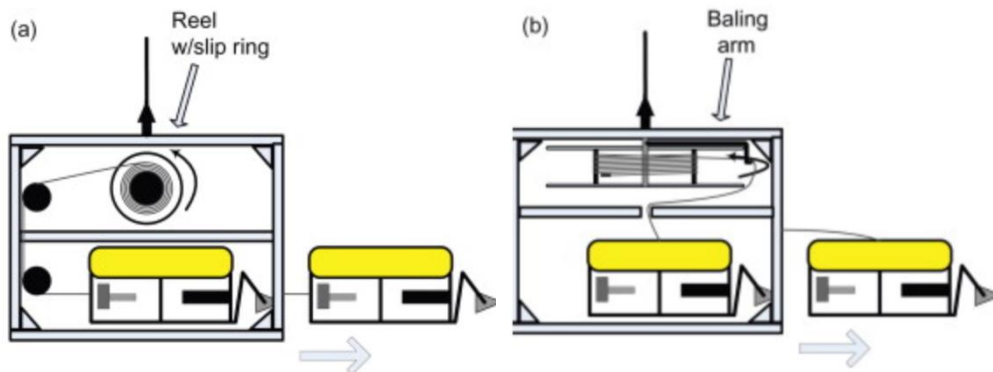

Figure 8. Underwater Micro-tether Payout Device Diagram (from Bowen 2009).

In Chapter 9 of The ROV Manual, two Tether Management Systems internal to a “cage” (a system that is lowered underwater from a winch from the main ship and manages the tether for the ROV) are discussed that can be seen in Figure 9 (Christ et al 2014). A reel with a slip ring has a rotary joint in the tether drum that rotates to spool and unspool tether, adding complexity but reducing wear. Alternatively, a baling arm can rotate around a stationary drum to spool and unspool tether, reducing complexity but increasing wear on the tether. Both these systems are bulky and actively controlled by a motor, as opposed to a minimum-diameter lightweight passive system needed for a Europa melt probe.



*Figure 9. Internal Tether Management Systems
(a) Reel/Slipping TMS (b) Bailing Arm TMS (from Christ et al 2014).*

NASA's Tunnelbot design contains a fiber optic tether integrated with three large repeaters (Oleson et al 2019). The fiber optic tether is wound around the repeaters which have an outer diameter of 12.66 cm, and the vehicle's outer diameter is 24.57 cm with the spool coaxial with the vehicle. The tether seems to unspool from the vehicle passively, although exact mechanisms and deployment are not specified.

Honeybee Robotic's SLUSH vehicle uses a fiber optic tether with the spools stored coaxial with the vehicle (Zacny et al 2019). SLUSH proposes three deployable spool bays that separate from the vehicle during descent and contain RF repeaters. Each spool bay would have tether optimized for certain sections of Europa's ice shell. The spool bay does not contain a motor, implying passive unspooling through an unspecified method.

Next Steps:

Further work must be done in miniaturizing fiber optic spooling systems that can pay out tether passively while minimizing volume. Passive unspooling of armored fiber optic from a vehicle must be tested in an ice environment for multiple kilometers, and the system must be capable of preventing tangles while avoiding wear and damage to the tether.

II.D. Lightweight, Corrosive-Resistant, Watertight Exterior Material Capable of Withstanding High Pressure

Context:

The structural integrity of an underwater vehicle is critical to keep the interior of the vehicle protected from intense pressures and a corrosive saline environment. The exterior must be rigid and reliable while being as lightweight as possible.

VERNE Context:

Both titanium and carbon fiber are materials being considered for the exterior cylindrical vehicle structure due to their high strength-to-weight ratios, corrosion resistance, and heritage in aerospace and deep-sea applications. To further reduce mass and provide effective insulation, an aerogel-filled honeycomb composite structure with aluminum face-sheets is also considered.

Technology Needs:

A Europa melt probe vehicle will require an exterior that can withstand a corrosive saline environment for multiple years while sustaining a wide range of temperatures from 90 K to 273 K and pressures greater than 18 MPa at 15+ km depth (Oleson et al 2019). Selecting an exterior material with minimal mass is critical to minimize mission cost and maximize scientific value.

Current Work:

The Compass Tunnelbot Report theorized multiple structural materials, including aluminum (Al 7075-T73), stainless steel (AISI 304), and titanium (Ti-6Al-4V) (Oleson et al 2019). Stainless steel was eliminated for being too heavy, and aluminum was decided against for its susceptibility to buckling and welding challenges, as it loses temper (thus strength) with welding. Titanium is most ideal given its radiation shielding, weldability, high modulus (providing buckling resistance), and high strength with only a small mass increase compared to aluminum.

Carbon fiber has been used in Earth oceanic applications such as Argo oceanography probes. A common Argo design is Teledyne Marine's APEX Current Profiling float, rated to 2000 m sea level (roughly 20 MPa) (Riser et al 2018), which is higher than the 17.9 MPa expected at 15 km below Europa's ice shell (Oleson et al 2019). Argo floats travel the oceans for 3-5 years continuously taking data, a demonstration of the corrosion resistance and durability of these pressure vessels.

Aluminum has been used as a structural material in ocean vehicles, including in the Antarctic under ice by the Icefin vehicle, similar in size and shape to an expected Europa melt probe vehicle. Hard-anodized 6061 Aluminum rated to 1500 m depth (~15 MPa) was used in ocean temperatures as low as -5 °C and air temperatures as low as -50°C (Spears et al 2016, Meister et al 2018).

Composite honeycomb structure with aluminum face-sheeting has been used in spacecraft application on Mars Science Laboratory and Mars Perseverance rover in the aero-backshell as well as the heat exchanger surrounding the RTG. Aerogel-filled Nomex-honeycomb between Al 7075-T73 face-sheets provided high-performance low-mass insulation that could be utilized on a Europa melt probe mission to insulate internal systems (Mastropietro et al 2010). Manufacturing difficulties could arise in shaping a honeycomb structure into a cylinder with a small radius of curvature, as well as the issue that welding aluminum reduces its strength. NASA has done extensive study of sandwich structures of composite face-sheets and foam core for lightweight high strength radiation and debris protection for space application that could be leveraged for aluminum and honeycomb structures (Atams et al 2007).

Aluminum coatings for corrosion resistance and environmental protection continue to advance. In addition to anodic coating and hard coating, plasma electrolytic oxidation is being studied for spacecraft applications, promising more durable and multifunctional surface characteristics (Shrestha et al 2010).

Next Steps:

Significant work must be done to advance knowledge of titanium, aluminum, and composite material behaviors in response to Europa's low temperatures, saline environment, and pressure. Laboratory testing of material responses as well as long-timescale field-testing must

be done to ensure material suitability to maintain structural integrity for the full mission lifetime. A full study of possible corrosive effects to materials from the European surface environment following in the footsteps of Luz Calle's "Corrosion on Mars: Effect of the Mars Environment on Spacecraft Materials" study would advance our understanding of material responses for Europa application (Calle 2019). And to minimize structural mass, developments must be made in more novel lightweight high-strength materials such as composites and honeycomb sandwich structures and then tested in a comparable environment. Another consideration is selecting a material that has similar thermal coefficients to rest of the vehicle to minimize the problems arising from differing thermal expansion across the vehicle due to the wide range of temperatures to which the vehicle will be exposed.

III. Communication and Data Handling Technology Gaps

III.A. Compact Transmitter of Simple Acoustic Signals through Cryogenic Ice

Context:

For a vehicle traveling any significant depth in the European ice shell, a communication system to the surface is necessary to return data to Earth. Many Europa melt probe designs consider a fiber optic tether for low-mass high-data-rate communication to the surface. Shifts in the upper conductive ice layer pose a risk of shearing the tether, justifying a secondary communication system to reduce mission risk.

Radio Frequency (RF) and acoustic (sound wave) signals are both candidates for a secondary communication system. RF signals have the issue of significant attenuation, reducing communication range to just meters through aqueous environments expected in Europa's ice shell, such as water pockets (Schmidt et al 2011), saturated ice and salts (Chivers et al 2021, or temperate ice (Lishman et al 2013). RF signals are also more sensitive to the chemical properties of the ice and require more power, making acoustic communication an attractive but underdeveloped choice.

For any communication system, the larger the distance between transmitter and receiver, the more power is needed, making direct communication between the vehicle and surface infeasible. One solution is for the vehicle to drop off transmitters at regular intervals that act as communication relays to the surface. Acoustic transmitters are commonly used in air and water communication, but to date have not been used to communicate through ice.

VERNE Context:

The VERNE vehicle would utilize acoustic communication pucks spaced every 900 m in the ice shell as a backup to the fiber optic tether:

The Wireless Acoustic LinK through Ice on Earth and Europa (WALKIEE) pucks are self-contained wireless acoustic receivers and transponders powered by a small battery system. As needed, the

pucks are heated by lightweight Radioisotope Heater Units (RHUs), insulated by silica aerogel, and use an outer structure made of Delrin. Primary lithium batteries with power densities of around 700 W-hr/L and a minimum temperature of -55 °C were selected as the reference power supplies. By analyzing an integrated link budget, the optimal puck specifications include a maximum separation distance of 900 m, a transmit power of 70 mW, a carrier frequency of 5 kHz, and a QPSK modulation scheme ... A WALKIEE prototype has been fabricated and tested in air and across ice in the lab with commercially available off the shelf (COTS) parts, and further testing will occur in ice over 2021 (Schmidt et al 2021).

Figure 10 shows the WALKIEE acoustic puck concept.

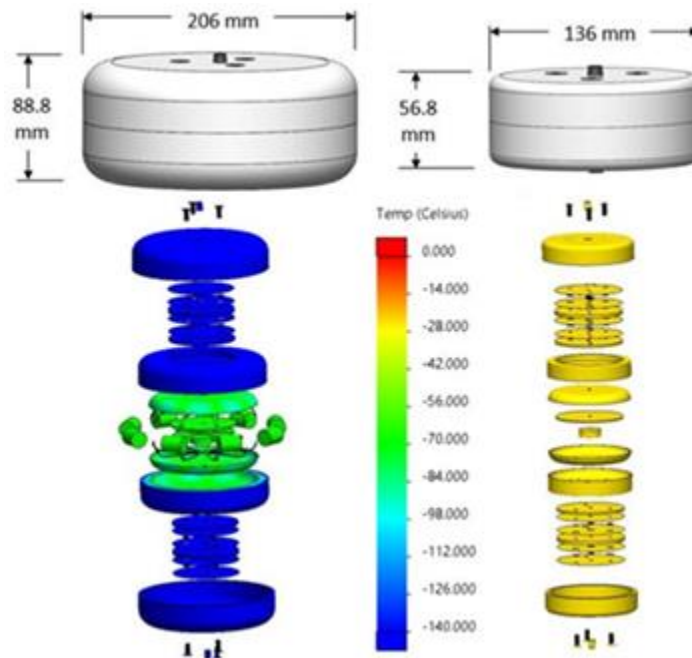

Figure 10. WALKIEE Communication puck design and Thermal Analysis. (a) Heated puck deployed in cryogenic ice; (b) Unheated puck deployed in temperate ice (from Schmidt et al 2021).

Technology Needs:

Acoustic transmitters must be developed to be self-contained with onboard power and must be able to survive and communicate in a wide range of ice temperatures on Europa (90 K to 273 K), all while being compact and capable of communicating over hundreds to thousands of meters in ice with low power consumption.

Current Work:

The South Pole Acoustic Test Setup (SPATS) in Antarctica, in collaboration with IceCube, consists of strings of acoustic transmitters and sensors spaced across multiple boreholes to detect neutrinos (Abdou et al 2012). Each SPATS stage, shown in Figure 11, contains an acoustic transmitter and sensor, with a steel pressure housing for electronics of outer diameter 101.6 mm. The entire stage has a length of 1.5 m, maximum diameter of 160 mm, and a mass of 10

kg. The power source and additional electronics are stored in a weatherproof box on the surface of each borehole. 6-8 SPATS stages are spaced from depths of 80 m to 400 m, with the power consumption per string ranging from ~35 W to ~96 W when all modules are powered on. The transducer elements are made of “lead zirconium titanate (PZT) material, namely PIC151, ... a soft piezo-ceramic material with a high piezoelectric charge constant, high permittivity and a high coupling factor.” The average transmitter power operates in the 20-60 kHz range. SPATS has been operating for over 5 years and demonstrates acoustic transmitters operating in low temperatures and high pressures, however with offboard power and acting as a scientific instrument, not for data communication purposes.

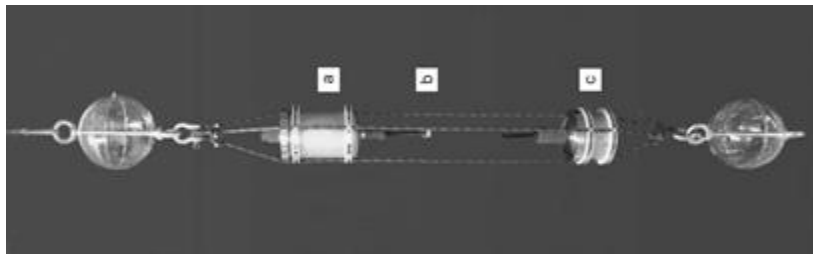

Figure 11. Fully assembled SPATS stage showing the transmitter module (a), the transmitter (b) and the sensor module (c) (Abdou et al 2012).

A study to characterize the attenuation of soundwaves in ice was conducted between the frequencies of 2 kHz and 35 kHz in an Italian glacier (Meyer et al 2019). Acoustic emitters and receivers were placed into holes multiple meters deep and covered by 30+ cm of water to refreeze in:

Two spherical, 4.25-inch, acoustic transducers of type ITC-1001 from the International Transducer Corporation used for sending and receiving the signals. This type of transducer provides a high-power broadband acoustic omnidirectional emissivity from 2 kHz to 38 kHz and equally good receiving properties (Meyer et al 2019).

Transmitters and receivers were spaced between 5 m to 90 m laterally apart in the glacier, all at a depth of 2-3 m. All power, processing, and data acquisition was done by electronics housed in weatherproof boxes on the surface. The signals used to test attenuation were Barker codes (autocorrelating discrete signals used to synchronize patterns between emitter and receiver) and chirp signals (sinusoidal signals with linearly increasing frequency) from 2 kHz to 38 kHz. The tests were consistent with others glacier attenuation studies from very different regions, showing an increase of attenuation with temperature and a slight increase of attenuation with frequency. This study characterized acoustic signals in terrestrial glacier ice, but from near the surface of the glaciers with offboard power and processing, with results that may not translate to the differing ice environment of Europa.

In a study to determine the feasibility of wireless acoustic transmitters deployed in Greenland ice sheets, communication was determined feasible in the 4 Hz- 40 kHz range, with higher frequencies likely to improve efficiency (Lishman et al 2013). The acoustic transmitter

used was a “Neptune Sonar T257 transducer, powered by a 400 W Vibe Marien Space amplifier” using transmission frequencies of 10-30 kHz placed 1 m beneath surface ice. Results showed transmission through 1 km of ice required 1 W of electrical power output. However, attenuation was found to be highly geographically and ice composition dependent, and the European ice composition and temperature would likely lead to very different results.

Aachen University’s previously mentioned EnEx-RANGE (Enceladus Explorer Initiative- Robust autonomous Acoustic Navigation in Glacial ice) project utilized a network of Autonomous Pinger Units (APUs) to assist the IceMole vehicle in navigation (Weinstock et al 2020). Each APU is housed in a cylindrical stainless-steel pressure vessel that can withstand a pressure of up to 20 bar, has an outer diameter of 8 cm, and a total length of 90 cm. The IceMole vehicle uses four 780 kHz phased resonant piezo arrays for obstacle detection of up to 15 m in water ice. Both IceMole and the APUs use acoustics in ice, though the signals only traveled small distances and were used for obstacle detection instead of transmitting data.

Next Steps:

This work demonstrates and characterizes acoustic transmission laterally in terrestrial glaciers. However, this behavior may not extrapolate to a European environment with much colder ice, and different ice composition and structure. Significant work must be done in miniaturizing transmitters for these environments while accommodating onboard power and testing in European representative environments.

III.B. Higher Areal-Density Radiation-Hardened Memory Storage

Context:

Improvements in memory storage technology have happened by leaps and bounds over the recent decades in the commercial computing market. However, those same increases have not been fully realized for space command and data handling applications. Harsh space environments can create extreme thermal environments and radiation damage through single-event upsets and accumulated radiation doses, events which terrestrial high-performance computing technology isn't designed for. Any spacecraft traveling to Europa will be exposed to years of space radiation as well as Jupiter’s intense radiation environment until the vehicle enters the ice shell, where radiation is minimal. During descent into the ice shell, electronics and memory storage will additionally need to operate in cold temperatures.

During descent, a Europa melt probe will be collecting large amounts of telemetry and scientific data for multiple years. If data transmission to the surface is bottlenecked by a broken fiber optic cable or slow data rates, the vehicle will generate valuable data faster than can be transmitted, requiring significant memory storage capability onboard to prevent valuable data from being overwritten. A Europa melt probe vehicle will need to minimize mass and volume in order to increase scientific capabilities and reduce cost, illuminating a need for large amounts of memory storage in a very small volume.

VERNE Context:

If the VERNE vehicle's fiber optic communication tether breaks, the system will rely on acoustic transducer pucks to communicate to the surface, throttling the data rate and leading to faster creation of valuable scientific and operational data than can be transmitted to the surface, creating the need for large robust storage capacity.

Technology Needs:

A memory storage system will need to be radiation hardened, tolerant of low temperatures, and fit into an extremely constrained volume. The estimated memory needed for a Europa melt probe mission is on the order of tens of gigabytes.

Current Work:

Work is being done at JPL to develop compact avionics for the Europa lander and ocean world missions capable of being stored at ambient Europa temperatures and conceivably reducing avionics volume by 10x, mass by 3x, and power by 2x (Bolotin et al 2018). Circuit board technology utilizing CoreEZ®, “a high-density substrate fabricated from thin particles containing organic laminates” instead of traditional glass cloth can allow for lower volume and higher channel density. The Manx Command and Data Handling System, shown in Figure 12, will be capable of withstanding 300 krads of radiation, fit in a 10 x 10 x 2 cm envelope, with an “EDAC [error-correcting] protected NAND flash [electronically re-writable] memory of 2 GBs for science and engineering telemetry”. Memory storage capacity for a melt probe may prove an order of magnitude higher, but even at a linear extrapolation, the system could fit into a melt probe vehicle envelope. Compared to a Europa lander, radiation exposure may be less severe due to the vehicle being protected by Europa's ice shell after ice insertion, easing development requirements.



Figure 12. JPL Manx Computer Card (a) Front (b) Back (from Bolotin et al 2018).

An alternative method to developing high-performance space-rated memory storage is to utilize existing commercial off the shelf (COTS) high-performance electronics in a radiation-tolerant architecture (Pignol 2010). The French space agency CNES developed thorough

validation techniques of lot acceptance tests, tests for single-event upsets and total integrated dose, destructive physical analysis, and thermal cycling to qualify COTS components for a space environment. System structures can be architected to cope with single-event upsets and make the overall system radiation tolerant, such as elementary protection mechanisms like watchdog timers used by NASA Small Explorer and the CNES MYRIADE micro-satellite. Other systems include Duplex or Triplex Architectures, where duplicate signals go through multiple separate processors, or alternatively, time delay two signals through the same processor to verify an answer. So far these radiation-tolerant architectures using COTS electronics have been deployed primarily in small low-Earth-orbit environments, where the mission timeline is short, and the radiation environment is less extreme than a Europa spacecraft would experience. For the near future, COTS memory storage technology may be difficult to validate and qualify for a Europa melt probe application due to the extremely low risk-tolerances of flagship missions.

Next Steps:

Continued development in low-temperature, compact, radiation-hardened avionics must be made to store necessary scientific data for a long-term Europa melt probe mission. Further technology improvements include reducing the areal density of memory storage and increasing the total storage capacity of radiation-hardened space-rated memory storage systems.

IV. Guidance Navigation, Control and Drilling System Technology Gaps

IV.A. Anti-Torque and Roll Stabilization

Context:

A Europa melt probe vehicle using a rotating mechanical drill requires a system to provide counter-torque. Without an anti-torque system, the drill motor would spin the vehicle body instead of the drill head when the drill encounters resistance. The most common method to apply counter-torque is by having a piece jutting from the non-rotating main body vehicle in contact with the borehole to apply sufficient friction to prevent the main body from rotating. Figure 13 shows different approaches gathered from a study investigating anti-torque systems of cable-suspended drills (Talalay et al 2014).

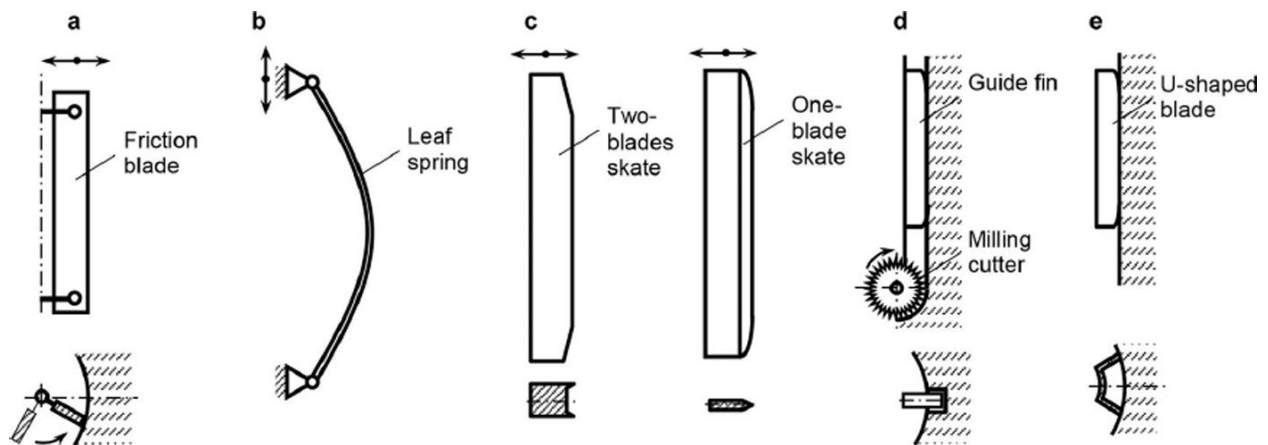

Figure 13. Types of Anti-Torque Systems: Types of anti-torque systems: (a) hinged friction blades; (b) leaf spring system; (c) skates; (d) side milling cutters; (e) U-shaped blade system (from Talalay et al 2014).

VERNE Context:

Leaf springs and skates have been assessed as the most promising designs for VERNE. Leaf springs function better in irregular or soft ice environments and require less volume, while skates have improved torque and resistance in constant density environments of harder ice (Talalay et al 2014).

Technology Needs:

To be effective in the Europa environment, an anti-torque system must be capable of operating in boreholes of varying diameter as well as ice environments ranging from extremely hard cryogenic 90 K ice to near-melting convective ice and slush. The system must also be extremely durable, operating for at least three years without repair or human intervention. A material

science challenge is finding material that is both durable and flexible across a wide range of temperatures while tolerating Europa’s saline environment.

IV.A.1. Durable Leaf Springs Capable of Sustaining High Loads at Low Temperatures

Current Work:

Multiple leaf spring anti-torque systems have been deployed on cable-suspended ice drills, exhaustively listed in Table II, including US’ CRREL, US’s Eclipse drill Denmark’s UCPH, and China’s CHINARE systems (Talalay et al 2014).

Table II. Leaf Spring Anti-Torque Systems used for Ice-Coring Drills (Talalay et al 2014).

Type (country)	Number of springs	Distance between hinges mm	Thickness × width of leaf spring mm	Source
CRREL (USA)	3	760	NA × 38	Rand (1976)
UCPH (Denmark)	3	500	2 × 20	Johnsen and others (1980)
ISTUK (Denmark)	3	690	2.5 × 20	Gundestrup and others (1984)
LGGE (France)	4	720	NA	Gillet and others (1984)
NHRI (Canada)	3	930	5.2 × 38	Holdsworth (1984)
PICO-4-inch (USA)	3	815	3.2 × 25	Litwak and others (1984)
PICO-5.2-inch (USA)	6 × 2	NA	NA	Wumkes (1994)
JARE (Japan)	3	640	2.5 × 25	Fujii and others (2002)
NGRIP (Denmark)	3	850	2.5 × 30	S. Hansen, personal communication (2014)
ECLIPSE (Canada)	3	NA	NA	Blake and others (1998)
BPRC (USA)	3	580–605	1.6 × 22.5	V. Zagorodnov, personal communication (2014)
DISC (USA)	4	510–522	2.4 × 25.4	J. Johnson, personal communication (2014)
CHINARE (China)	3	667	2.5 × 30	A. Takahashi, personal communication (2014)

Note: NA: data not available.

The Eclipse Drill ice coring drill from the U.S. Ice Drilling Program uses a metal leaf-spring anti-torque system shown in Figure 14, with extensive field-testing in Antarctic ice and proven success (U.S. Ice Drilling Program). The system is lowered down on a cable less than 300 m into ice of temperatures 200-250 K (Scambos 2020) for under 200 hours, compared to a Europa melt probe mission operating in temperatures of 90 K-273 K autonomously for at least three years, traversing up to 15 km.

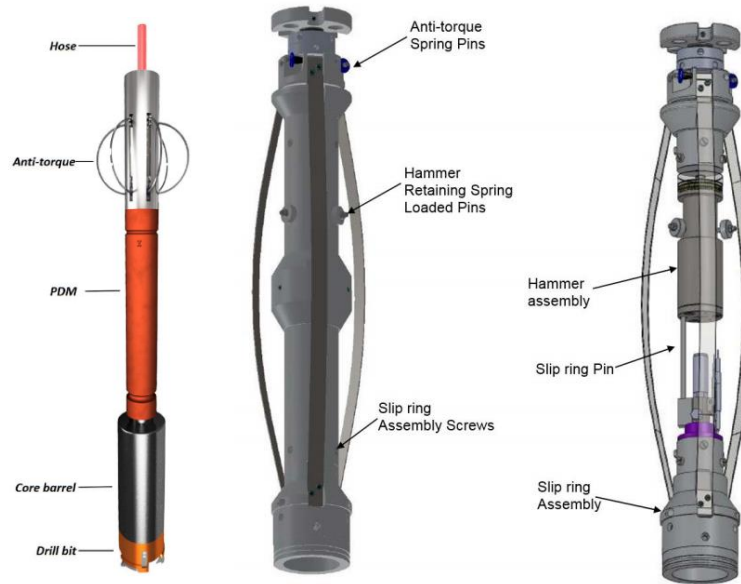

Figure 14. (a) Eclipse Drill ; (b) anti-torque leaf spring module (from Talalay et al 2014).

Leaf springs have seen niche space-rated applications in on-orbit telescope stabilization in cryogenic environments without repair, however, these leaf springs are fairly static, are not used for antitorque, are made of aluminum, and do not sustain significant load (Kroes et al 2017). In addition, the space environment is drastically different from Europa's ice environment, providing minimal validation of leaf springs in a European ice environment.

Studies from automobile applications have shown fiber-reinforced polymer-based matrix composite (carbon fiber) leaf springs have, compared to aluminum, higher corrosion and chemical resistance, reduced mass, and higher tensile strength under cyclic tensile loading (Soner et al 2012).

Next Steps:

Further work must be done in testing leaf spring systems that can withstand cryogenic temperatures and have a lifespan of at least three years in saline and ice environments like Europa.

IV.A.2. Anti-Torque Skates Capable of Handling Ice Chips and Slush

Current Work:

Skates have been used across a multitude of ice drills, exhaustively listed in Table III, including Switzerland's FELICS, the UK's BAS, USA's CRREL, and Japan's ILTS (Talalay et al 2014). Skate deployment can be actuated by springs, scroll plate and camshaft, or tensioned cable.

Table III. Skate Anti-Torque Systems used for Ice-Coring Drills (Talalay et al 2014).

Type (country)	Skate number; type	Skate length mm	Features of skate	Source
University of Iceland	3; non-retractable	150	Skates are pressed against borehole wall by steel springs	Árnason and others (1974)
Antarctic Division (Australia)	3; non-retractable	200	Spring behind skate pushes it against borehole wall	Wehrle (1985)
University of Bern (Switzerland)	3; retractable	NA	Skates are driven out to the wall by torque and the release of the cable tension	Schwander and Ruffli (1988, 1994)
KEMS (Russia)	3; non-retractable	350	Four-bar linkage; one spring forces to expand system; force between each skate and hole wall can be adjusted in the range 540–940 N	Kudryashov and others (1994)
BAS (UK)	3; retractable	NA	Skates are able to be withdrawn into housing under the weight of the drill hanging from cable	Mulvaney and others (2002)
FELICS (Switzerland)	3; non-retractable	600	6 uniform springs along the axis of skates push them towards borehole wall	Ginot and others (2002)
ILTS (Japan)	NA; retractable	NA	Pantograph design	Kohshima and others (2002)
USA CRREL (prototype)	4; retractable	NA	Skates are actuated by scroll plate which is attached to freely rotating gear reducer and provides cam action to the arms forcing skates out against borehole wall	Ueda (2002)
ITBR (China)	4; non-retractable	NA	Skates are made in the form of thin plate	B. Xu, personal communication (2014)

Note: NA: data are not available.

Issues identified with skate anti-torque systems include slipping in density-varying materials like slush (Kohshima et al 2002) and accumulation of flaking ice-chips, which can clog the borehole, increasing needed drill torque (Schwander et al 1988).

A combination of skates and leaf springs has the potential to operate in hard ice as well as softer firn. One method is to have passive leaf springs always pressed against the borehole while skates are deployed during active drilling. Another method is to attach skates to the leaf spring surface, which can prove more effective in transition layers between hard and softer ice (Talalay et al 2014).

Next Steps:

Anti-torque systems for ice core drilling have been used extensively in the field, however further work must be done in autonomous anti-torque systems that can operate without human intervention in cryogenic ice environments. Some combination of skate and leaf spring designs must be tested to ensure they provide anti-torque in a wide variety of environments and do not generate more ice chips than the vehicle can handle, or that cause the vehicle to freeze into the ice. An additional direction to explore is investigating thermal resistor integration into the antitorque system to prevent freezing into the ice.

IV.A.3. Counter-Rotating Ice Drill

Context:

Another method to reduce torque from a rotating drill is to have the drill split into upper and lower sections. These sections rotate in opposite directions and are driven by separate motors, reducing the net torque and load transferred to the anti-torque system.

VERNE Context:

The VERNE vehicle utilizes a counter-rotating drill head shown in Figure 15, with the upper and lower section driven in opposite directions by separate motors.

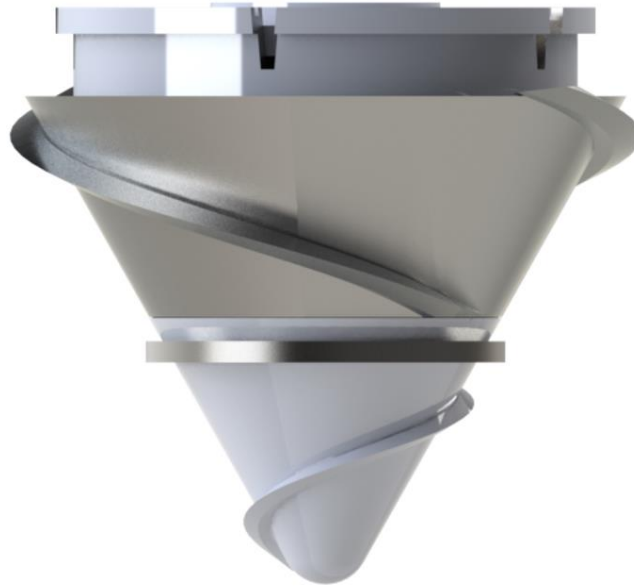

Figure 15. VERNE Counter Rotating Drill Concept.

Technology Needs:

The drill must be designed to ensure the upper and lower sections produce nearly equal torques under a wide range of operating conditions. Net torque can occur if the two sections do not have equal contact with the ice because the drill is (a) at the ice surface, (b) in an uneven salt environment, or (c) in very warm ice where the melt pocket could be expanded too large. Therefore, the heating of the drill must be carefully controlled to create a steady melt pocket forward of the drill in different ice temperatures.

The drill must also prevent particles from wedging between the two drill sections, where they could stall the drill or damage the internal system. Optimal clearance between the drill sections minimizes friction between the rotating sections while still ensuring effective chip transport between sections.

Current Work:

A small-scale prototype of a counter-rotating thermo-mechanical drill head intended for Europa ice application was tested in an ambient as well as vacuum laboratory setting in a study

led by Peter Weiss (Weiss et al 2011). A 4 cm wide drill with a 15 W motor drove an upper and lower drill propeller rotating opposite directions. The system had a rectangular body to prevent rotation in the borehole and counter the remaining net drill torque. Test drilling through sand had to be halted to prevent damage to the internal gears, shown in Figure 16, when particles entered the space between the two drill sections. These tests focused on the novelty of a thermo-mechanical drill and did not focus on the effectiveness of the counter-rotating drill head. Future tests are intended to be done with a single non-counter-rotating drill, as the rectangular body was deemed sufficient for anti-torque for the scale of the experiment. This test successfully demonstrates a counter-rotating thermo-mechanical drill head on a small scale in the laboratory.

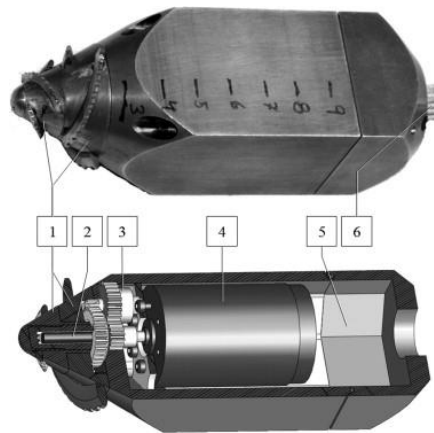

Figure 16. The thermal drill prototype and its internal components: (1) rotary blades, (2) cartridge heater (four others in the corners are not shown), (3) gear, (4) motor, (5) tether compartment, and (6) cable (from Weiss et al 2011).

Next Steps:

Counter-rotating thermo-mechanical ice drills must be further studied in a laboratory setting to ensure they continue operating under a wide range of conditions and the full mission lifetime without repair. Tests must then scale up to full Europa mission size and be tested in field environments and then in environments and conditions resembling Europa's ice shell.

IV.B. Mechanical Drill System

IV.B.1. Auger-like Chip Transport on the Drill

Context:

For a Europa melt probe vehicle to move down through the ice, the ice in front of the vehicle must be displaced and moved to the rear. If this does not happen, the drill simply stirs a pile of ice chips without the ability to move downward. To ensure mission success, a drill must be designed that can transport ice chips and encountered salts to the rear of the vehicle under a range of operating conditions.

VERNE Context:

The VERNE drill's counter-rotating upper and lower sections have auger-like teeth to carry ice chips above the drill. The overall drill is slightly wider than the vehicle to allow unmelted ice chips to travel along the length of the vehicle unhindered. The clearance between the drill and vehicle width is 1 cm, allowing 99% of ice chips to flow unblocked along the vehicle.

Technology Needs:

A chip transport system capable of moving ice chips from the drill head of the vehicle to behind the drill and past the vehicle is necessary for a Europa melt probe mission. An auger-like system of drill teeth on a conical drill head is considered to be a viable solution. The drill head must be slightly wider than the vehicle to allow unmelted ice chips to flow along the vehicle body and must be able to operate in a wide variety of environments from cryogenic and convective ice to possible salt deposits. The drill head must have high cutting efficiency across these different materials and thermal environments while having a minimal clearance in the borehole and work within the constraints of the vehicle power and envelope while preventing any stall scenario. For a counter-rotating drill, a chip transport system must lose minimal ice chips between the upper and lower sections.

Current Work:

Jongkuk Hong investigates optimization and modeling of ice chip transport on electromechanical augers in polar glacier environments (Hong et al 2014). There is a trade-off between a higher auger angle that maximizes transport efficiency and a lower auger angle that reduce the number of cuttings that build up at the drill base. There is a similar tradeoff between faster rotation generating faster chip transport but producing more disordered chip transport where chips fall off the drill in the clearance between the borehole wall back to the bottom.

Honeybee Robotic's Search for Life Using Submersible Heated (SLUSH) drill is currently testing a thermomechanical drill for a Europa melt probe vehicle (Zacny et al 2018). Instead of moving ice chips by an auger, SLUSH breaks ice up into small chips with a cylindrical rotary-percussive drill, then captures the ice chips inside the probe and melts them into slush that flows around the vehicle, reducing heat loss to the borehole and eliminating the need of transporting ice chips. The SLUSH drill head, shown in Figure 17, has successfully been laboratory tested on 90 K cryogenic ice, with an observed energy efficiency of fourteen times a purely thermal drill.

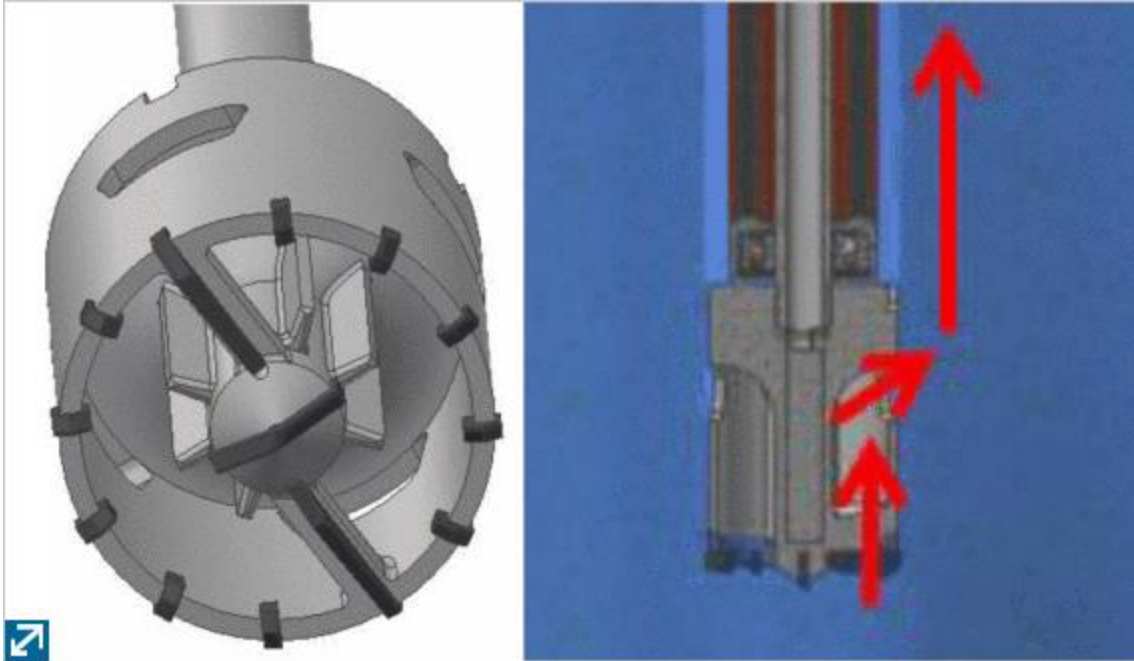

Figure 17. SLUSH Chip Transport Method (from Zacny et al 2018).

Peter Weiss led a small-scale study of a counter-rotating conical thermomechanical drill head tested in laboratory environments in ice and sand (Weiss et al 2008). The teeth of the drill, however, were not auger-like although they did have some chip transporting function. Depth penetrated did not exceed the scale of centimeters and the vehicle itself was only 4 cm wide, so extrapolating to a large vehicle drilling tens of kilometers for multiple years would be erroneous.

Next Steps:

Conical drills with auger-like chip transport must be tested in Europa-like conditions, including cryogenic 90 K ice, convective ice close to 273 K, and salt deposits of varying thickness. Full-scale tests will need to be done and drilling tested to depths of meters to kilometers to fully quantify and understand chip accumulation and possible motor stalling. Large-scale tests in the field and in cryogenic ice may prove resource intensive, however, they are necessary to mitigate the risk of a stall that could cause drill failure during a Europa mission.

IV.C. Side-Mounted Forward-Sensing Systems

Context:

For a Europa melt probe to sense when it's approaching the ice-water interface as well as to detect obstacles, the vehicle requires the ability of forward-sensing, of "seeing" ahead of itself. Two methods to accomplish this are sonar and radar.

Sound navigation and ranging, or sonar, is a method of sending out sound waves and detecting obstacles and the surrounding environment by listening to how those sound waves

reflect off objects. A radio detection and ranging, or radar, system uses the same methodology with radio waves instead of sound waves. Radar has significant precedent for in-ice detection applications: ice is largely transparent to radio signals, allowing mapping of areas with changes in density and material properties such as boundaries, water bodies, and obstacles.

For a Europa melt probe mission design utilizing a rotating drill head, sensors cannot function properly if placed in front or behind it due to interference. Instead, sensors must be placed on the side of the vehicle and be capable of a wide observation angle to detect obstacles (such as the ice-water interface) ahead of the vehicle. In general, a wider observation angle reduces the sensitivity of the sensor (thus smaller distances that can be observed), presenting a challenge to develop a system that both can detect objects at long range and have a wide angle of sensitivity.

VERNE Context:

Forward-sensing is complicated by the fact of VERNE having a metal rotating drill head, making the possibility of mounting a sensor on the drill head difficult. Sonar is sensitive to the medium the signal travels through, and performance is significantly hampered between mediums with significantly different acoustic properties, including metal, ice, and water. To mitigate this, “coupling” between mediums is needed, allowing as direct contact as possible. This is difficult for VERNE, as a transducer cannot be directly mounted rotating metal drill head. Placing the transducers on the sides of the vehicle requires minimizing losses between the water layer around the vehicle and the ice, with a wide enough cone angle as shown in Figure 18 to still “see” forward and long enough range to detect the ice-water interface in time to deploy the anchoring device into the ice shell.

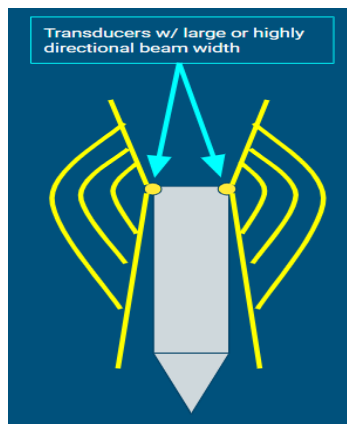

Figure 18. Wide Angle Beam With Side Facing Transducers.

Technology Needs:

The side-mounted forward-sensing system must be capable of detecting the ice-ocean interface at a long range (ideally >100 meters) while minimizing volume, power consumption, and the blind spot cone ahead of the vehicle.

IV.C.1. Long-Range Wide-Angle Sonar

Current Work:

Aachen University's IceMole concept is a small melt probe being developed as part of the Enceladus Explorer project, capable of melting curved trajectories through ice and using piezo transducers in an Acoustic Reconnaissance System (ARS) to navigate through ice and detect obstacles up to 15 meters range in water ice (Kowalski et al 2016). IceMole has the advantage of a stationary melt head, allowing more coupling of transducers placed directly on the front of the vehicle to the forward ice. The IceMole team intends to redesign its original four 780 kHz phased resonant piezo arrays, altering the number of elements and resonant frequency, trading improved range for decreased lateral resolution.

In tandem with IceMole, Aachen University is developing Autonomous Pinger Units (APUs), cylindrical acoustic transmitter devices deployed in a network surrounding IceMole's trajectory allowing it to trilaterate and position itself relative to the network (Weinstock et al 2020). Melt heads on the APUs make them capable of descending in the ice to reshape the network, allowing for optimal localizing of IceMole. Terrestrial glacier tests of this acoustic system provide valuable information for in-ice acoustic transmission behavior, however, the application towards forward-sensing for a Europa melt probe is limited.

Next Steps:

For a rotating drill, a forward-mounted acoustic transducer appears challenging. Body-mounted acoustic transducers must be investigated and must enable longer range detection while maintaining sufficient resolution. Methods to increase performance include improving the medium-coupling of acoustic transducers to the ice and reducing losses due to the water film between the transducer and the ice environment.

IV.C.2. Compact Radar Capable of Identifying Close Distance Objects

Current Work:

Stone Aerospace's VALKYRIE robot is a vehicle intended to penetrate Europa's ice shell, using an external laser transmitted via glass fiber to heat the vehicle and meltwater, allowing the vehicle to traverse via active hot water jet or passive melting. VALKYRIE uses a Synthetic Aperture Radar (IceSAR) in the Ultra-High-Frequency range developed by CU-Boulder to detect obstacles (Pradhan et al 2016). VALKYRIE's design places the radar system in a log-periodic folded slot array shown in Figure 19, shaped as five spaced rings flush with the outer body behind the relatively radar-transparent ceramic melt head. IceSAR also accounts for a thin pocket of water ~1.5 cm thickness around the vehicle, an important consideration as water significantly different transmission properties from ice.

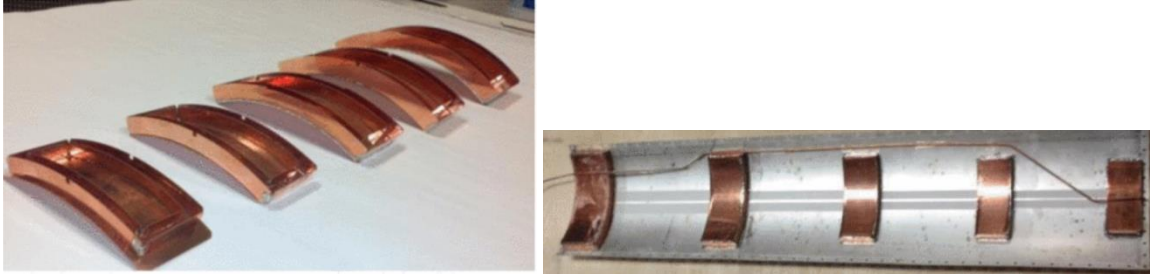

Figure 19. IceSAR Log Periodic Folded Slot Array (a) resonant cavities (b) antenna panel (from Pradhan et al 2016).

ApRES (Autonomous phase-sensitive Radio-Echo Sounder) is “a robust instrument specifically designed for long-term, autonomous operation in extremely cold environments” (Bagshaw et al 2018) as low as $-40\text{ }^{\circ}\text{C}$ (Nicholls et al 2015) used for wireless subglacial temperature and pressure measurement. ApRES is further suited for harsh glacial conditions with waterproof casing and minimal power consumption by always being in an ultra-power-saving state except for chirp communication every two hours, with quality communication through firn of up to 50 m (Bagshaw et al 2018). ApRES and similar work such as ETracer and Cryoegg sensor devices have field-proven experience in the Greenland ice sheet, proving relevance for cold temperature in-ice wireless radio devices for autonomous long-term low power operation with a small form factor. However, this application is limited as these devices used radio for communication, not radar or obstacle detection, and are only rated for $-40\text{ }^{\circ}\text{C}$, not the $-160\text{ }^{\circ}\text{C}$ expected in Europa’s upper ice shell.

Next Steps:

To enable a Europa melt probe mission, miniaturization must occur to achieve a usable form factor, and efficiency improvements of low-frequency electrically small antennae must be made. A low frequency necessary to penetrate the meltwater layer surrounding the vehicle must be balanced with a high enough power to receive useful data. These systems must be autonomous, operate with low power, and operate without repair for multiple years. A parallel research path is developing processing techniques that would be able to eliminate interference from a metallic drill head to allow increased visibility in the forward direction.

V. Electrical Power System Technology Gaps

V.A. Compact Finless Radioisotope Thermoelectric Generators (RTGs)

Context:

Electrical power is a necessity for a spacecraft to move as well as collect and transmit scientific data. For a Europa melt probe mission, solar panels are infeasible, as solar radiation is weak so far from the sun and the vehicle will be under the surface. Solely relying on batteries for multiple years of operation would make the vehicle prohibitively massive and costly, leading to the need for the vehicle to generate its own power for the duration of the mission. Nuclear systems offer multi-year duration high-energy-density power, in the form of non-reacting RTGs that convert heat from nuclear decay to electricity, or small-scale fission reactors that create large amounts of energy from chain reactions of splitting atoms.

An RTG, in essence, is a pellet of plutonium surrounded by ceramic material (creating a General Purpose Heat Source, or GPHS) that generates a significant consistent amount of heat from nuclear decay. Thermocouples surround the heat source, generating electricity from the voltage difference created by certain metals when subjected to a large temperature differential between the heat source and ambient environment.

VERNE Context:

VERNE has opted to study a Radioisotope Thermoelectric Generator (RTG) solution over small scale-nuclear reactor solutions (ex. NASA's 1 kW 400 kg Kilopower reactor concept) to prioritize a higher Technology Readiness Level concept that would be launch-ready in the coming decades.

Multi-Mission RTGs (MMRTGs) are capable of operating in both planetary atmosphere and vacuum. MMTRG technology is quite old, only 5% efficient at converting heat to electricity, and uses large heat rejection radiator fins that would need to be removed by redesign for a Europa melt probe mission that needs minimal diameter and to retain heat for onboard use.

Technology Needs:

A Europa melt probe mission requires a redesign of the MMRTG to remove radiator fins and instead use an active cooling loop. A decreased diameter would allow a smaller mass and power of the overall system, as the primary driver of the vehicle's power requirement is its diameter, which determines the volume of ice that needs to be displaced. Increased efficiencies would allow either greater power thus increased mission capability, or reduced mass thus reducing mission cost.

Current Work and Next Steps:

Current RTG technology development programs being investigated by NASA Glenn Research Center include a Finless MMRTG concept, an Enhanced MMRTG (eMMRTG), a Next

Generation RTG, and a Dynamic Radioisotope Power System, (DRPS), with specifications shown in Table IV.

Table IV. Radioisotope Thermoelectric Generator Specifications (“Enhanced Multi-Mission Radioisotope Thermoelectric Generator (eMMRTG) Concept”, “RPS Orbital and Surface Power”, “Finless RTG Power System Concept”, Zakrajsek et al 2017).

	MMRTG (“Enhanced Multi-Mission Radioisotope Thermoelectric Generator (eMMRTG) Concept”)	Finless RTG (“Finless RTG Power System Concept”)	eMMRTG (Enhanced Multi-Mission Radioisotope Thermoelectric Generator (eMMRTG) Concept”)	Next-Gen Sectioned Modular RTG (Zakrajsek et al 2017)
Number of GPHS Modules	8	8	8	16, modular in groups of 2
BOM Power (W)	110	110	~145	500
EOL Power (W)	60	73	>90	362
Mass (kg)	45	49	44kg	62
Length (m)	0.69	0.59	0.69	1.04
Electrical Production Efficiency (%)	6	6	8	12-15
Power Conversion Technology (Thermocouples)	PbTe/TAGS	PbTe/TAGS	Skutterudite (SKD)	Options of SKD, LaTe/composite, 14-1-11 Zintl
Power Degradation Rate (%/year)	4.8 (“RPS Orbital and Surface Power”)	2.5	2.5 (“RPS Orbital and Surface Power”)	1.9
Heat Q (W)	2000	2000	2000	4000

A Finless RTG would replace radiator fins with an active cooling loop, decreasing its overall diameter from 65 cm to 23 cm and length from 69 cm to 59 cm (“Finless RTG Power System Concept”). Due to the significant amount of heat generated by an RTG, radiator fins traditionally are needed to reject heat and keep the overall system from melting for space or planetary surface spacecraft, whereas a Finless RTG for melt probe missions retains heat and minimizes vehicle diameter. In the case of a Europa melt probe, all the RTG heat will be captured by a mechanically pumped fluid loop to keep subsystems within temperature ranges, heat the drill head, and prevent the vehicle from freezing to the surrounding ice. Limited information is public about a Finless RTG design, but according to a Finless RTG Power System

Concept Factsheet, essentially the only change from the existing MMRTG is the removal of fins, slight decrease in length, and improved End of Life power from reduced degradation rate, as shown in Table IV. Currently, no work is being done on developing a Finless RTG, though a feasibility study is being conducted on reducing the fin length of Dragonfly's MMRTG by NASA's Radioisotope Power Systems (RPS) program. Developing a Finless RTG is one of the most critical steps to enabling a Europa melt probe mission and should be among the highest priorities set for NASA's RPS group if a near future Europa melt probe mission is desired.

The enhanced MMRTG (eMMRTG) concept replaces the MMRTG's existing thermocouples material of PbTe/TAGS with Skutterudite (SKD) and adds a surface oxidation layer to the heat source inner liner as well as changing insulation, allowing for higher hot junction temperatures thus increasing electrical power output by over 25% at beginning of life (BOL) and over 50% at End of Life (EOL), with added metrics shown in Table IV ("Enhanced Multi-Mission Radioisotope Thermoelectric Generator (eMMRTG) Concept"). eMMRTG development was originally targeted for completion in 2019 with the development process split into a formulation, maturation, and refinement phase, followed by the creation of a qualification unit. A Status Update report of the eMMRTG published in March 2019 states the formulation phase of demonstrating manufacturability of SKD was completed in 2015 (Matthes et al 2019). eMMRTG development has been paused to focus on further developing the SKD thermoelectrics and testing a 48-thermocouple module.

The Next Generation RTG concepts include several improvements making RTGs segmented and modular (Zakrajsek et al 2017). A Segmented RTG (SRTG) integrates several different thermoelectric materials in each thermocouple, increasing the efficiency and electrical power output. A modular design would allow flexibility across a wide range of mission designs, from a low power small mission needing only 2 GPHSs to large 16 GPHS missions generating up to 500 W of power with a mass of 62 kg and an efficiency double that of the existing MMRTG, with further specifications included in Table IV. Both modularity and segmentation increase complexity, thus risk and cost, to RTG development. However, the resulting performance and mission flexibility hold significant value in enabling planetary science missions. Further material testing and design are being done to advance the Next Gen RTG to TRL 4 by 2023. If the technology is promising enough to pass review, a qualification unit will begin development aimed for 2029 completion, increasing TRL from 4 to 8 (Zakrajsek et al 2019).

Dynamic Radioisotope Power Systems (DRPSs) opt for mechanical conversion from heat to electricity by a Stirling engine instead of using thermocouples ("Dynamic Radioisotope Power Systems"). DRPSs promise over 20% electrical conversion efficiency, 3-4x more than MMRTGs. DRPSs, with a mass of 90 kg, currently take up a larger volume than RTGs, which would make application difficult for a minimal diameter Europa melt probe mission. Moving parts in the engine also pose complications for an uncrewed deep-space mission, though NASA Glenn Research Center has been testing high endurance Stirling engines that have been running continuously for over ten years, showing the issue can be overcome. Two companies

contracted to develop Stirling-type DRPS engines with non-contacting piston bearings are Sunpower Inc. and American Superconductor. Prototypes of these were expected to be delivered in 2020. If review is passed, development of a qualification unit would begin in 2021 to be completed in 2024, increasing TRL from 3 to 8 (Zakrajsek et al 2019). NASA, partnering with the Department of Energy and Idaho National Laboratories, is currently developing system-level concepts through industry contracts with a with a possibility of qualifying a DRPS by 2030.

V.B. Low-Temperature Rechargeable Batteries

Context:

A Europa melt probe vehicle will most likely be severely power-constrained, and a rechargeable battery can store enough energy to allow high-power components to operate intermittently. A rechargeable battery can also allow the operation of parts of the vehicle that routinely detach from the vehicle's power source, such as a water profiler.

Lithium-ion batteries are high energy density batteries that are widely used in consumer electronics and have flight heritage on space missions. A challenge of lithium-ion batteries is their temperature sensitivity. They can only operate at optimum efficiency in a narrow temperature range, and high efficiencies have not been demonstrated in the low temperatures seen in Europa's ice shell.

VERNE Context:

The VERNE vehicle will travel downward in Europa's ice shell to the ice-water interface of a water body, where the rear section containing the communications module will anchor into the ice. The remainder of the vehicle will conduct a controlled vertical profile of the water body using a winch and tether system. The profiling section of the vehicle generates all power and will transmit power to the anchored communications module through a tether. In case the vehicle is incapacitated or the tether breaks, the communications module shall have its own battery to power essential data transmission up to the lander even if the vehicle itself is lost. The rechargeable battery shall be "topped off" constantly with power from the vehicle, serving a secondary function as part of the power control and distribution system.

Technology Needs:

To operate in Europa's upper ice environment (as cold as 110 K), the battery must be capable of withstanding low temperatures in the range of -60 °C to -80 °C (M. C. Smart et al 2019) while maximizing specific energy to minimize mass.

Current Work:

Lithium-ion batteries have not flown in space with operating temperatures below -30 °C. The Mars Insight Lander landed in 2018 with an NCA battery rated from -30 °C to +35 °C and specific energy of 120 Wh/kg (M. C. Smart et al 2019), while the highest performing small

battery launched was a 6.5 kg LCO battery used on Kepler with an operating range of -10°C to 45°C and specific energy of 90 Wh/kg (Surampudi 2017). JPL has verified benchtop battery performance of 150 Wh/kg specific energy at -40 °C and a specific energy of 100 Wh/kg at -60 °C to -70 °C.

Next Steps:

Department of Energy labs and the battery industry are looking towards low-temperature electrolytes that can conduct ionically in a film on the electrode (Surampudi 2017). Using solvents with low viscosity and melting point and additives to increase stability and kinetics at low temperatures promise improved performance in colder environments. These technologies could enable batteries with specific energies of 150-200 Wh/kg with an operating range of -60 °C to 30 °C.

V.C. Low-Temperature High-Energy-Density Primary Batteries

Context:

Primary (non-rechargeable) batteries are devices that convert stored chemical energy to electrical energy and cannot be recharged afterward. Primary batteries have higher energy densities and a wider operational temperature range than rechargeable batteries. They are used in spacecraft applications for short one-time activities, for very low power consumption uses over a very long time, or when there is no way to recharge the system.

For a Europa melt probe mission, primary batteries are needed for any powered system that permanently disconnects from the spacecraft, such as communication repeater pucks. Multiple melt probe mission designs such as Cryobot (Cwick et al 2018) and Tunnelbot (Oleson et al 2019) envision repeaters in the ice shell to communicate between the surface and the vehicle and as a backup in case the primary fiber optic tether breaks. Tunnelbot envisions three large repeaters that contain Radioactive Heating Units (RHUs) and Stirling engines that convert heat to electrical power, avoiding the need for a battery (Oleson et al 2019).

VERNE Context:

VERNE similarly envisions repeater pucks in the ice shell as backups to the fiber optic tether, however, these repeaters would be smaller and at every 1 km in the ice shell, requiring 15 small repeaters instead of three large ones. A Stirling power conversion system takes significant mass and volume, and would be infeasible for these smaller repeaters, therefore primary batteries to power the repeater pucks from deployment to end of mission would be needed.

Technology Needs:

In the VERNE design, repeater pucks in the upper cryogenic ice shell will need batteries that can operate with -80 °C internal temperatures, balancing insulation and battery volume

needs, with an energy density of roughly 800 W-hr/L for a very constrained data rate, or 2400 W-hr/L for the desired 500 Mbit/day data rate, assuming minimal temperature degradation.

Current Work:

NASA JPL's *Energy Storage Technologies for Future Planetary Science Missions* report by Surampudi contains thorough descriptions of ongoing work on battery systems that are summarized below (Surampudi 2017).

Low-temperature lithium-ion batteries such as Thionyl Chloride (Li-SOCl₂) have the potential to operate at temperatures as low as -100 °C, enabled by low-freezing-temperature electrolytes tested by JPL, with promising energy density (>350 Wh/L) and long lifespan. Currently, Li-SOCl₂ batteries have been demonstrated at -60 °C by JPL by the New Millennium Deep Space-2 program in the late 90's and could deliver 25% of room temperature capacity at -80 °C. As of 2017, further using LiGaCl₄ salt to lower the operating temperature to -100 °C is possible, although neither NASA, DoD, nor industry is actively researching this technology.

Lithium-Carbon Monofluoride (Li-CFx) batteries promise reduced mass and volume by up to 70% over Li-SOCl₂, with the tradeoff of a minimum operating temperature of -40 °C. Current Li-CFx batteries perform poorly at low temperatures and have low room temperature discharge rates. The NRO and Army-CECOM laboratories are currently the only groups working on the task of improving specific energy and low-temperature performance of this technology.

Lithium-Carbon Monofluoride Hybrid (Li/CFx-MnO₂) batteries promise an operating low temperature of -60 °C with high energy density and up to 50% mass and volume reduction compared to Li-SOCl₂. They trade off slightly lower energy density than Li-CFx for increased safety and discharge rate. Energy densities of 900 Wh/L have been demonstrated, and significant work is being done on these systems by industry including EaglePicher and Ultralife funded by the DoD.

Next Steps:

The following are excerpts from the *Energy Storage Technologies for Future Planetary Science Missions* 2017 report regarding the recommended technical direction of battery development going forward (Surampudi 2017).

Thionyl Chloride (Li-SOCl₂):

In order to improve the low temperature performance of these (Li-SOCl₂) batteries, alternate electrolytes and improved cell designs are needed. Addition of suitable solvents/co-solvents, use of alternate electrolyte salts, and controlling the purity of the electrolyte are anticipated to minimize voltage delay and improve the low temperature performance (Surampudi 2017).

Lithium-Carbon Monofluoride (Li-CFx):

In order to provide planetary missions with Li/CFx primary batteries that have high specific energy (>700 Wh/kg), moderate power densities (>200 W/kg), long life (10–15 years), and the ability to operate in low temperature environments (to –80°C), the research and development efforts should focus on the following areas:

- new electrolytes and additives that enhance the ionic conduction and reduce the passivation effects of cathode to improve the rate capability;
- modified electrode designs with dense electrodes; thin current collectors and lightweight cell cans for enhanced specific energy and energy density;
- evaluation of alternate cathode and binder materials and seals to improve the radiation tolerance, development of robust cell designs to withstand high shock levels
- understanding the effects of radiation or high-temperature exposure to develop methods for planetary protection (Surampudi 2017).

Lithium-Carbon Monofluoride Hybrid (Li/CFx-MnO₂):

In order to provide PSD with Li-CFx-MnO₂ hybrid primary batteries that have high specific energy (>600Wh/kg), moderate power densities (>200 W/kg), long life (10–15 years), and the ability to operate in harsh temperature environments (to –60°C), developments should focus on the following areas:

- New electrolytes and salts that enhance the ionic conduction and reduce passivation effects of the cathode to improve rate capability and low temperature performance.
- Modified electrode designs with dense electrodes, thin current collectors, and lightweight cell cans for enhanced specific energy and energy density.
- Optimization of CFx to MnO₂ ratio in the cathode.
- Evaluation of alternate cathode and binder materials, as well as seals, to improve the radiation tolerance.
- Development of robust cell designs to withstand high shock levels.
- Enhancing the understanding of the effects of radiation or high-temperature exposure to develop methods for planetary protection (Surampudi 2017).

VI. Thermal Management System Technology Gaps

VI.A. Mechanically Pumped Fluid Loop for Heat Transfer to Rotating Drill Head

Context:

For Europa melt probe designs that desire to melt the ice ahead of the vehicle, heat must be transferred from the heat source to the nose. This can be done by a fluid loop as part of a thermal management system. A thermal management system is also critical to maintain subsystem temperatures within operating ranges, to prevent damage to scientific equipment and electronics, and to provide heat to the vehicle exterior to prevent the meltwater layer from refreezing and trapping the vehicle.

Existing ice-penetrating drills used on Earth provide energy on the surface of the ice which is then transferred to the drill. This comes either in the form of heating fluid that is pumped through the drill, a high-powered infrared laser that is absorbed by the metal of the drill and converted to heat, or electric power which is converted to heat via a thermal resistor. Ice drilling systems on Earth tend not to have onboard power systems nor do they require self-contained thermal regulation. Both increase probe complexity and cost and are typically unnecessary for Earth systems since it is possible to easily offload these functions to the surface. A Europa mission using onboard nuclear power would require a self-contained thermal management system, and a thermal drill would require the transfer of heat to the nose of the vehicle.

VERNE Context:

The VERNE design proposes onboard Radioisotope Thermoelectric Generators (RTGs) whose heat would be transferred to the nose of the vehicle via a closed-loop, single-phase, mechanically pumped fluid loop filled with CFC-11, a cooling fluid with precedent on other RTG-using space missions such as Curiosity. Heat would need to be transferred to the counter-rotating thermo-mechanical drill head from the non-rotating fluid loop. A method that accomplishes this is shown in Figure 20. Fluid is released from the mechanically pumped fluid loop to a layer between the stationary vehicle core and the rotating drill head, where heat transfer can occur between the hot fluid and drill surface before the cooled fluid reenters the fluid loop. This design would need to account for turbulence, boundary layers, and the Coriolis force which could produce vortices and Taylor columns, effects that cause flow disruptions and reduce heat transfer.

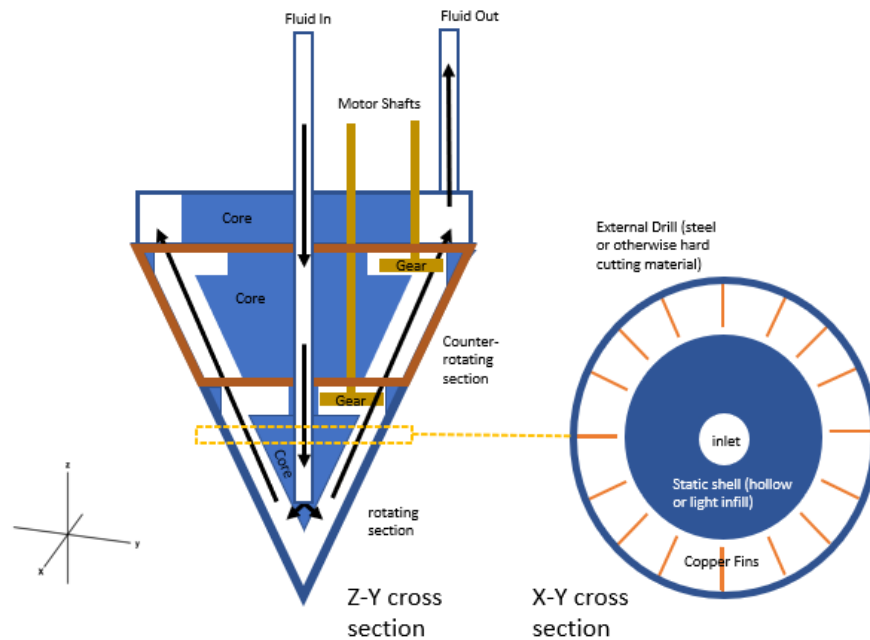

Figure 20. VERNE Heat Transfer to Drill Concept.

Technology Needs:

A Mechanically Pumped Fluid Loop (MPFL) for a Europa melt probe vehicle must be capable of transferring the heat produced by a nuclear power source to the nose of the vehicle at high efficiency and minimal sidewall losses. The MPFL must be able to operate continuously for multiple years and have minimal mass, volume, and power consumption.

Current Work:

NASA's Mars Science Laboratory (MSL) rover contains an MPFL circulating the heat produced by a Multi-Mission RTG (MMRTG) using CFC-11 cooling fluid in the Martian atmosphere (Bhandari et al 2013). Unlike a Europa melt probe, the MSL rover does not require all the heat produced by the RTG, so its thermal management system incorporates heat rejection. The Heat Rejection System, seen in Figure 21, contains hot plates that absorb radiation emitted by the RTG and a fluid loop, which warms electronics and instruments before rejecting excess heat through a cold plate by convection and radiation to the ambient Mars environment. The system used two pumps consuming a total power of 10 W. The plates are made of aluminum with an insulating composite honeycomb structure, filled with an aerogel, preventing heat transfer directly from the hot plate to the cold plate. This system demonstrates an MPFL used for thermal management of an RTG on board a spacecraft. A difference from a Europa melt probe mission is the environment: a thin Martian atmosphere ranging in temperature from 150 K to 311 K, compared to a European environment of ice ranging from 110 K to 273 K. A Europa melt probe, if using RTGs, would have its thermal loop collect heat by

direct contact with the RTGs instead of radiation. A Europa melt probe thermal management system must also transfer a significant fraction of RTG heat to the nose and ensure the vehicle exterior is sufficiently warm to prevent freezing, issues not considered for the MSL mission.

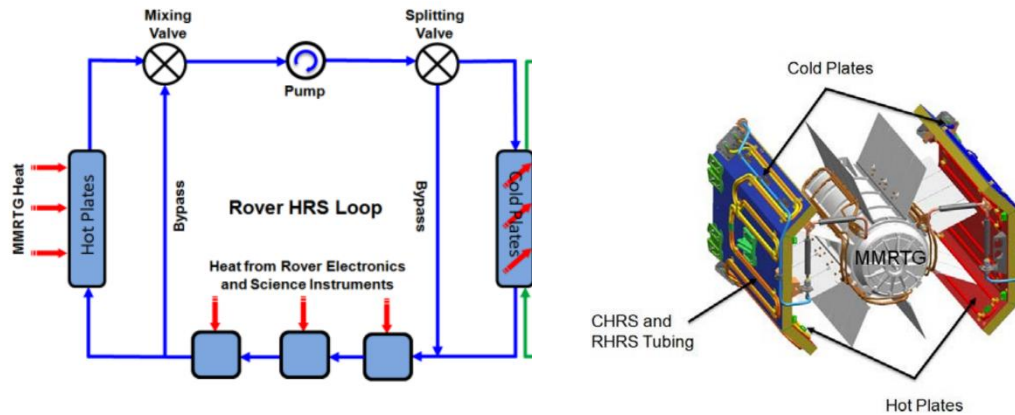

Figure 21. Mars Science Laboratory Heat Rejection System (a) Schematic (b) 3D Model (from Bhandri et al 2013).

Stone Aerospace’s VALKYRIE project utilizes a high-power laser and beam dump mechanism that absorbs infrared light transferred via fiber optic cable converting it into heat (Stone et al 2014). This heat is then transferred to meltwater that flows in small micro-channels inside the beam dump. The meltwater is pumped by diaphragm pumps, which can either advance the vehicle forward by jetting the hot water forward or circulate the hot water in order to heat the nose of the vehicle and act as a melt probe. Figure 22 shows a 3D model of the system and the machined beam dump made of “T6061 T6 aircraft alloy aluminum and a heat-resistant, photon-absorbing, non-off-gassing anodized coating”. The meltwater diaphragm pumps require 2-4% of the system’s total 5000 W_{optical} of power transmitted via fiber optic tether. The pumps were selected such that they produce high pressure with a low power input and low current. They were also selected for their reliability under long-term continuous operation, and because they continue functioning even in the presence of debris. The pumps are powered by Maxon’s 310009 motors that are “4.7 cm diameter × 20 cm length and [are] capable of pumping 6 L/min at 345 kPa over ambient pressure”. VALKYRIE’s pumps have been tested in the lab continuously for hundreds of hours. This is in addition to testing conducted with a VALKYRIE field prototype at Matanuska Glacier in Alaska in 2014 and 2015 (Stone et al 2018). The differences from VERNE’s design, in this case, are that the VERNE system would operate a closed thermal loop of CFC-11, whereas VALKYRIE has an open loop of meltwater that must consider debris. VALKYRIE heats the fluid from the beam dump with embedded meltwater channels that are exposed to a high-power infrared laser, while VERNE collects heat by convection of a thermal loop in contact with the RTG which is then dumped into the drill head.

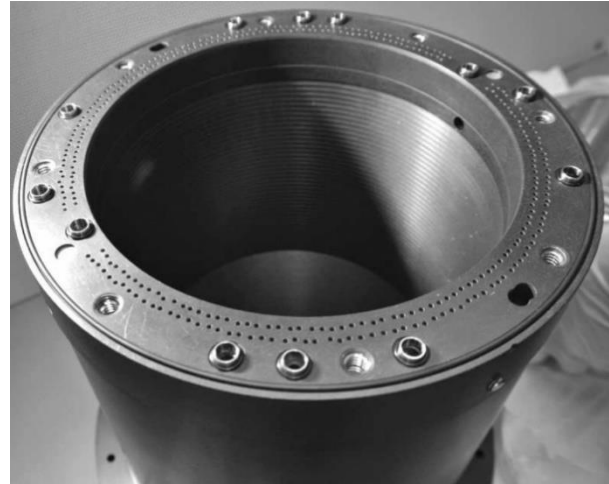
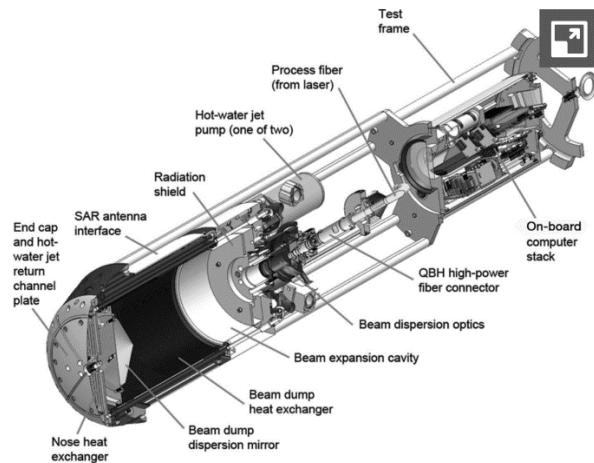

Figure 22. VALKYRIE Heating System a) 3D Model b) Beam Dump (from Stone et al 2014).

Stone Aerospace's follow up to the VALKYRIE project, SPINDLE, proposes a cryobot designed for penetrating 4 km deep into Europa's ice shell before depositing an autonomous underwater vehicle into a European lake. SPINDLE intends to incorporate nuclear power in the form of either a Radioisotope Power System or fission reactor but will use a high voltage power line from the surface for prototyping and testing. SPINDLE, differing from VALKYRIE, will have a closed thermal loop using a low-freezing-point process-fluid heated by high-voltage contact plates. These plates will transfer heat to the open meltwater loop which will be used for water jetting, as shown in Figure 23. The closed-loop utilizes a centrifugal high-volume low-pressure pump, while the meltwater open-loop uses high-volume high-pressure diaphragm pumps. This thermal system has been tested in the laboratory on a sub-scale Prototype High-voltage Ice Lance (PHIL) system shown in Figure 24 (Stone et al 2018). Differences from the VERNE design include direct heating of the thermal system by high voltage power instead of convection from an RTG, in addition to the use of the open-loop meltwater for water jetting instead of heat transfer to a drill head.

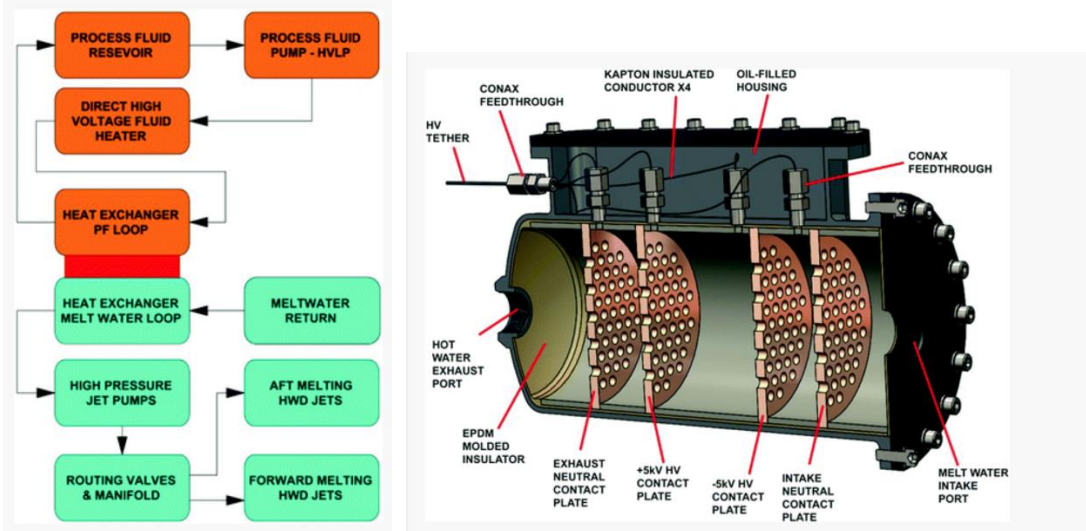

Figure 23. SPINDLE (a) Water Heating Schematic (b) Direct High Voltage Fluid Heater (from Stone et al 2018).

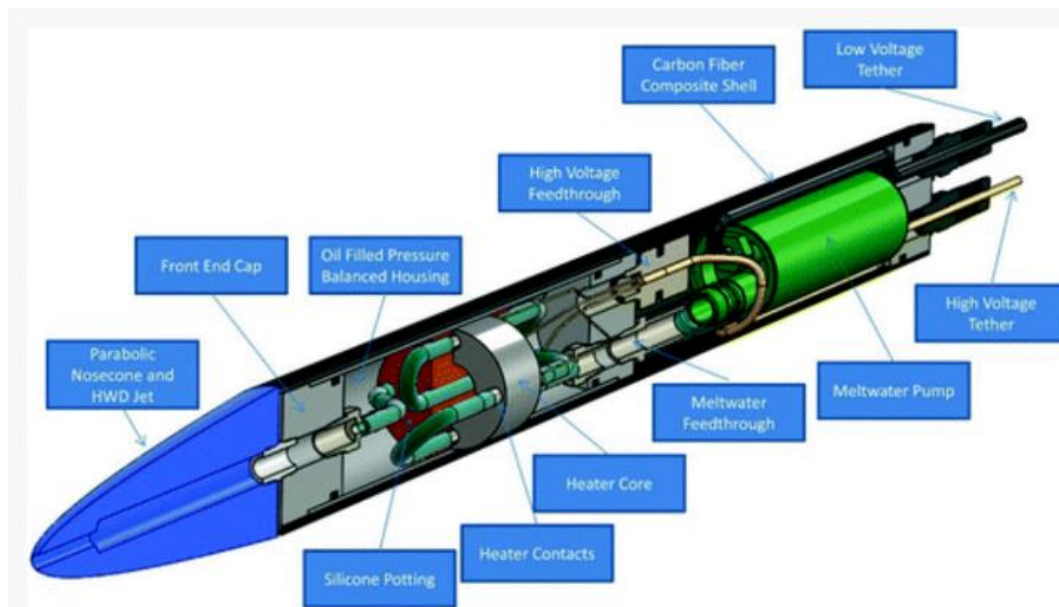

Figure 24. Prototype High-voltage Ice Lance (PHIL) 3D Model (from Stone et al 2018)

The IceCube Firn Drill is a terrestrial system using a conical melt head composed of copper tubing that carries heated glycol, shown in Figure 25 (Benson et al 2014). This mechanism created over sixty boreholes, 60 cm in diameter and 50 m deep, through low-density snow (firn) at the South Pole. The system has its power and heating systems on the surface and transfers heated glycol by hose line to the drill at high pressure and large scale, pumping approximately 600 L/min.

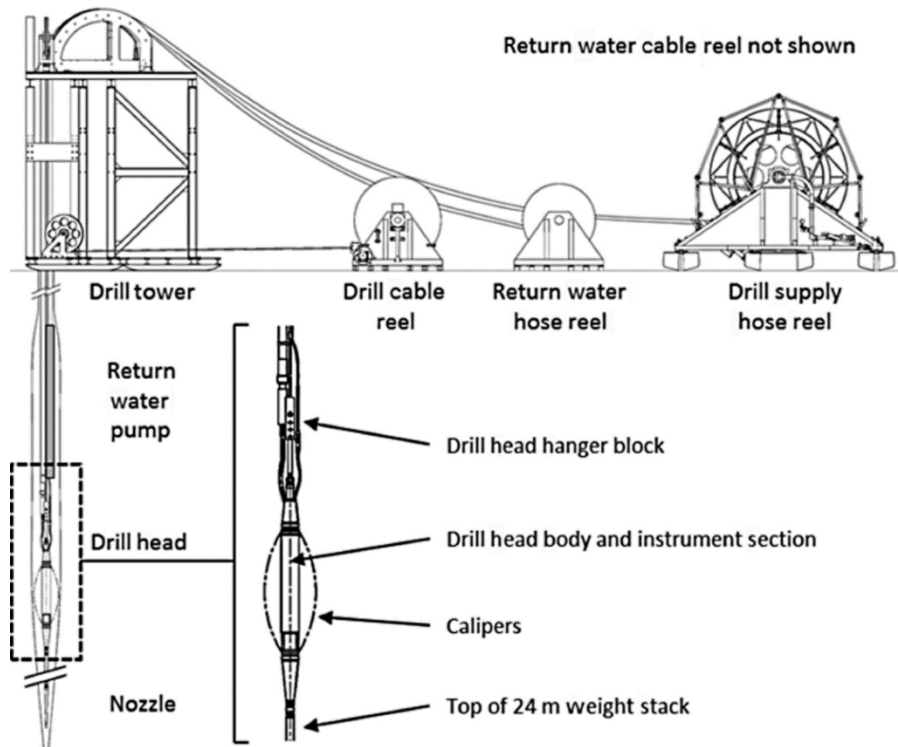

Figure 25. Ice Cube Firn Drill Surface and Downhole Equipment (from Benson et al 2014).

Peter Weiss of Hong Kong Polytechnic University led a study for the creation of a counter-rotating thermo-mechanical drill small-scale prototype designed for European ice that has been tested in a laboratory environment (Weiss et al 2009). Four cylindrical cartridge thermal resistors at the base of the drill head (and one located axially in the center of the drill) are used to heat the system, shown in Figure 26. This is the only counter-rotating thermo-mechanical drill designed for a European application that has been built and tested at any scale, though significant scaling up and integration of a thermal loop system in a similar vehicle would be needed to demonstrate the feasibility of the design for full-scale European application.

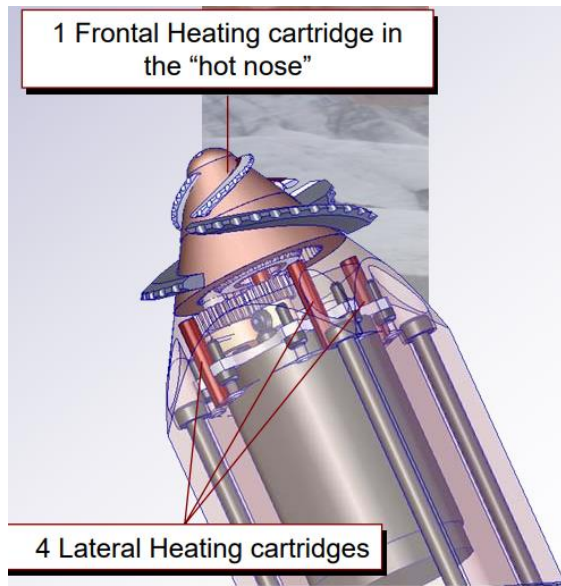

Figure 26. Thermistor Heating System for Counter-Rotating Thermomechanical Drill (from Weiss et al 2009).

Next Steps:

Mechanically pumped fluid loops using RTGs for space application have been used in space applications, but technology development and testing of thermal loops transferring heat into the nose of a Europa melt probe-like vehicle, using a nuclear or nuclear-representative heat source, would need to be conducted in laboratory as well as field environments. To advance the design of a thermo-mechanical drill using nuclear power, significant work must be done to design and test systems that allow the transfer of heat by a non-rotating fluid loop to a rotating drill head. Low-power, high-reliability pumps that can fit into a Europa melt probe spacecraft must be designed and tested to ensure long life.

VI.B. Light-Weight Corrosion-Resistant Thermal Hot Plate

Context:

For a Europa melt probe vehicle using a nuclear heat source tunneling through kilometers of cryogenic ice, managing the vehicle's internal and external temperatures are mission-critical. For a vehicle generating a melt-pocket in the ice shell, a means of ensuring the meltwater doesn't refreeze along the exterior and trap the vehicle is additionally necessary. One approach is incorporating hot plates in the vehicle exterior. This would require the implementation of metal plates that are in contact with fluid loops that transfer heat from the heat source to the vehicle exterior, maintaining the vehicle exterior above the freezing temperature of the water. The large surface area of the plates combined with the necessary thickness to contain thermal fluid piping would require the hot plate to have a significant volume, making the density of the material a large factor in the overall vehicle mass.

VERNE Context:

The VERNE vehicle uses four sets of hot plates in line with the vehicle exterior to maintain the skin temperature above freezing. Thermal fluid channels interior to the hot plates are utilized as a part of VERNE's mechanically pumped fluid loop system, shown in Figure 27. Titanium was selected as the material of choice for its high strength, relatively low density, and corrosion resistance.

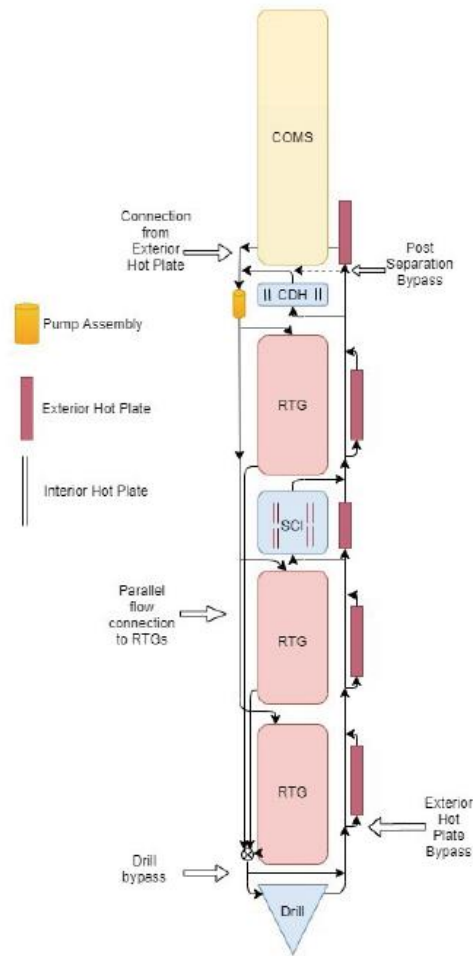

Figure 27. Conceptual schematic of VERNE thermal system containing hot plates (Schmidt et al 2021).

Technology Needs:

The hot plate must be low density while also having sufficient strength to maintain the structural integrity of the vehicle. It must also be corrosion resistant in anticipation of years of exposure and possibly be capable of being additively manufactured if complex fluid channel geometries become necessary.

Current Work:

3D printed titanium structures have been demonstrated for cold marine applications as well as aboard satellites. Sciaky's 3-D printed titanium tanks use Electron-Beam Additive Manufacturing, melting metal feedstock into a desired pattern via electron-beam gun one layer at a time, controlling for microstructure and mechanical properties. Cold marine applications have been demonstrated by Canada's Arctic Explorer system with their variable ballast tank, rated to a depth of 5000 m, experiencing low temperatures and similar pressures to what a Europa melt probe may experience. Lockheed Martin has used Sciaky's large 3-D printed titanium tanks for satellite propellant storage, demonstrating their suitability for space-related applications (Sciaky 2021).

Next Steps:

3-D printed titanium structures have been successfully demonstrated in Europa-like environments. However, complex geometries needed for thermal plate fluid channels must be manufactured using this technology, and corrosion resistance in a saline environment must be proven for a multi-year mission. Other materials capable of being shaped into complex geometries that are lightweight, corrosion-resistant, and sufficiently strong may also be considered for this application.

VII. Science and Sample Handling System Technology Gaps

Context:

This section summarizes the work done in the paper “Subsurface Science and Search for Life in Ocean Worlds” (SSSLOW) led by Justin Lawrence and Andrew Mullen of Georgia Tech (Lawrence et al 2021). The paper discusses opportunities and challenges for science and sample acquisition for subsurface oceans on icy worlds. It additionally surveys relevant technology needed to accomplish scientific goals of searching for life, assessing habitability, and investigating geology on worlds such as Europa. For a detailed exploration of the work done in this area, the reader is referred to the full paper.

Technology Needs:

Scientific instruments on a Europa melt probe vehicle must be able to tolerate a wide variety of conditions including launch, spaceflight, high-pressure liquid environments, and possibly corrosive salts and deposits. The instruments need to operate highly autonomously, sample with high resolution in unsteady terrain, and be able to detect low concentrations of biosignatures (Lawrence et al 2021).

Assuming an ice shell of 35 km thickness, pressures experienced by the vehicle could reach 40 MPa, much higher than pressures of other planetary environments but similar to pressures at the mean depth of Earth's oceans (~4000 m), which existing oceanographic instrument suites routinely operate in. Some methods existing marine scientific instruments use to handle these pressures include “(1) be pressure-balanced by oil filling or eliminating void space, (2) perform observations through a viewport in a pressure housing or (3) operate within a pressure housing on samples that have first been depressurized” (Lawrence et al 2021).

The sample acquisition system must also be capable of handling salts, dust, and debris in the ice shell as well as trapped gasses:

In a brittle conductive lid (<3 km) [Europa’s upper ice layer], “the vehicle may encounter fractures or voids, or tens of meters thick liquid lenses and or meters thick salt layers... Salt deposits could further saturate the melt pocket around the vehicle, modifying the stability of organic compounds, increasing the fluid viscosity and corrosion potential, inducing solid salt precipitation, and necessitating sample desalting for some instruments (Lawrence et al 2021).

Other technology needs include being able to conduct science with delayed and limited Earth communication, requiring a high degree of autonomy of when to take samples opportunistically, and how to prioritize power, resources, and data to return. Additionally, the instrument suite may need to detect life in incredibly low biosignature concentrations, estimated for Europa at 0.1 to 100 mL⁻¹, in comparison to low-biomass terrestrial ice accumulated on Lake Vostok of 10 to 1000 mL⁻¹ (Lawrence et al 2021).

Current Work:

Multiple projects are currently advancing instrument development for Europa missions funded by NASA's COLDTech, ICEE, and ICEE 2 programs:

Prototype payloads for landed missions include the European Molecular Indicators of Life Investigation (EMILI) (Brinckerhoff et al. 2019) and the Ocean Worlds Life Surveyor (OWLS) system (Creamer et al. 2020; Willis et al. 2019) which combines molecular analysis and imaging of liquid samples. High fidelity concept payloads for surface ocean world missions include the Europa Lander and Enceladus Orbilander (MacKenzie et al. 2020). Community guides (Hendrix, et al. 2019; Neveu et al. 2018), research networks (NFOLD, NOW), and white papers (Howell, et al. 2020; Schmidt, et al. 2020a; Schmidt, et al. 2020b; Willis, et al. 2020) also provide valuable prioritization for life detection payload development (Lawrence et al 2021).

Many field-tested oceanographic science vehicles and petroleum exploration systems are applicable to high-pressure sampling in a European environment. Relevant multi-instrument platforms include:

The Environmental Sample Processor (ESP) (Scholin et al. 2017; Ussler III et al. 2013), Argo profiling floats (Roemmich et al. 2019; Roemmich et al. 2009), underwater vehicle Icefin (Meister et al. 2018; Spears et al. 2016) and vehicles for hydrothermal vent exploration (Yoerger et al. 2007). Ocean world analog missions are presently working to integrate subsurface access drills with scientific payloads to operate in ice (e.g. Malaska et al. 2020; Stone et al. 2018; Winebrenner et al. 2013; Wirtz & Hildebrandt 2016). Downhole fluid analysis (DFA) packages for in situ sampling and flow-through chemical measurements are also extensively employed in high pressure petroleum exploration and production applications (Creek et al. 2010).” Additional petroleum exploration technology that could be relevant includes “In situ logging or measuring while drilling (L/MWD) instruments [that] are designed at small diameters for extremely high pressures (> 200 MPa), low (2-5) pH environments, and high shock and vibration. Typical observables include density, resistivity, seismic propagation, and fluid properties (Gooneratne et al., 2019). Profiling these material properties during the ice shell traverse would contribute significantly to our understanding of ice shell structure, transport processes, and formation history (Lawrence et al 2021).

A swath of individual life detection-relevant and sampling technologies applicable to an icy world subsurface payload exists across a wide range of different scientific fields. A table detailing an extensive survey of these technologies compiled in the SSSLOW paper is included in the appendix (Lawrence et al 2021).

Based on a thorough survey of existing tools relevant to ocean world exploration and the scientific goals of searching for life, assessing habitability, and investigating geology on ocean worlds, a SSSLOW payload concept is presented in Figure 28.

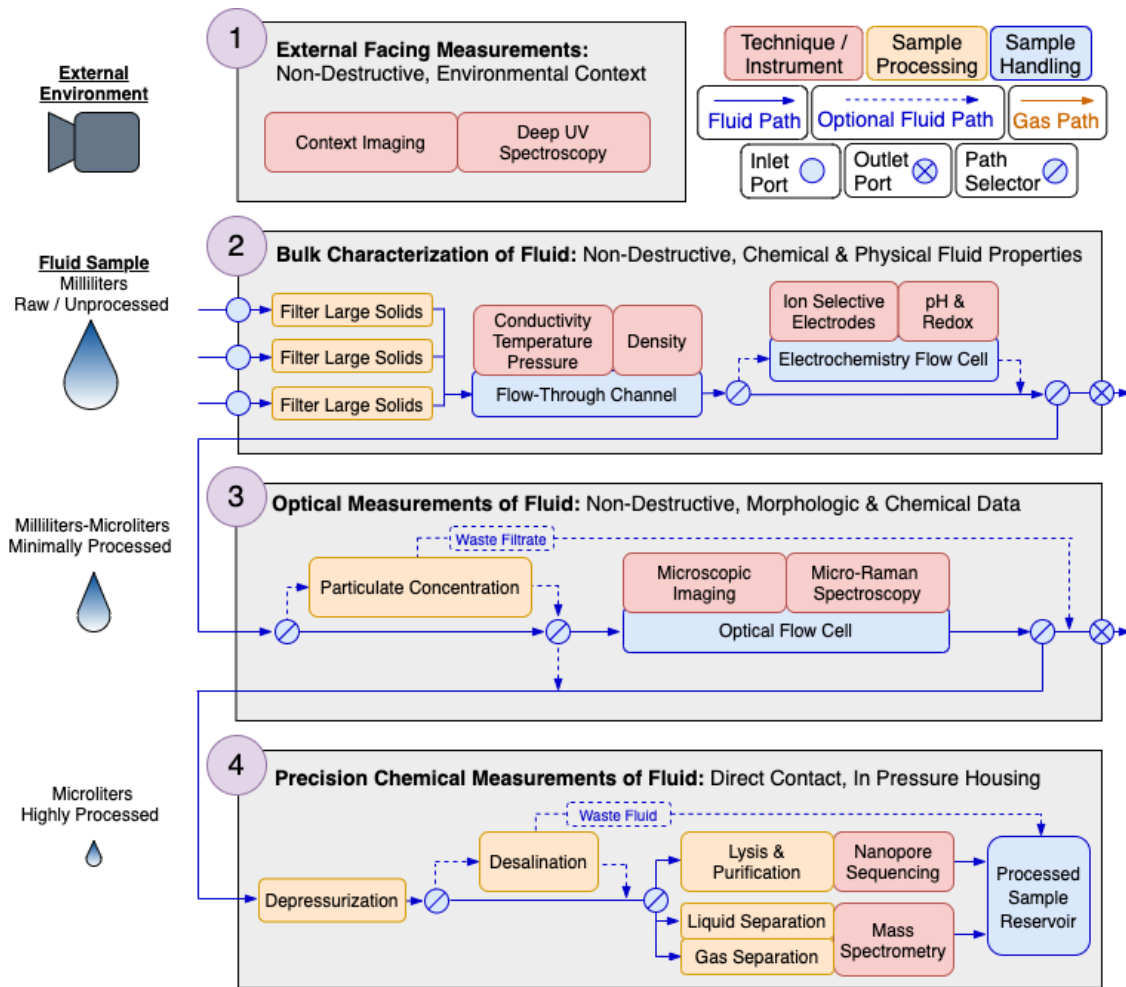

Figure 28. Conceptual diagram of the Subsurface Science and Search for Life in Ocean Worlds (SSLOW) Payload (from Lawrence et al 2021).

The methodology for payload concept selection is described below:

The instrument suite was designed to make observations across relevant size scales (microbial aggregate, cellular, molecular), with varying sample alterations (natural ice matrix, melted, processed), and multiple measurement techniques (imaging, spectroscopy, spectrometry, sequencing). Fluidic instruments are routed in series such that multiple measurements can be compared for the same fluid volume. Operation in a submerged environment may require partially destructive sample alteration to meet instrument requirements, including depressurization and desalination, both of which may alter context and target signatures of life (e.g. cell lysis). To enable maximum preservation of context we have sequenced instrumentation and sample handling into four stages, ordered from least to most destructive such that the sample is modified only to the degree required for each additional measurement. At every phase, the system should intelligently select which samples to send downstream for additional measurements and reject samples with hazardous physical or chemical properties. This strategy builds the contextual understanding of the sample with each additional measurement and enables prioritization for continued analysis of samples with suspected biosignatures. The

payload is compiled from tools used in oceanography, glaciology, microbiology, and analytical chemistry in addition to hardware with spaceflight heritage or presently under development for ice and ocean world exploration (Lawrence et al 2021).

Next Steps:

Existing expertise must be leveraged across different scientific fields and industries to advance the capabilities of scientific instruments and sample handling systems towards a Europa melt probe mission. Early and consistent funding must be allocated to technology maturation projects such as increasing autonomous capabilities of small volume liquid sample collection and combining flow through and discrete liquid sampling for small volume systems, as well as autonomous desalting, depressurizing, and concentration of milliliter and microliter sized systems.

VIII. Conclusion

Jupiter's moon Europa holds incredible potential in the search for life beyond Earth and understanding ocean worlds. The keys to unlock this potential are largely technological, with advances on several fronts needed to enable a mission to penetrate the moon's ice shell and study the ocean beneath. Without intentional development of these technologies, a Europa melt probe mission will likely remain unattainable for multiple generations. This report identifies significant technology gaps that need to be closed to enable a Europa melt probe mission and provides a compendium of the current work developing this technology towards a Europa mission. This development manifests itself in a variety of ways, from ice-coring drills and rappelling robots to benchtop batteries and Antarctic arrays detecting neutrinos. While the impressive previous and ongoing work should be acknowledged, further development targeted towards Europa application is necessary if we wish to see what Europa's oceans hold in our lifetime. Next steps to develop the identified technologies are laid out, and if invested in early and consistently, could allow for the selection of a Europa melt probe mission as early as the decade 2033-2042.

IX. References

1. "Additive Manufacturing of Titanium Parts." <https://www.sciaky.com/additive-manufacturing-titanium-parts> (accessed Apr. 03, 2021).
2. "Dynamic Radioisotope Power Systems," NASA Radioisotope Power Systems. <https://rps.nasa.gov/resources/77/dynamic-radioisotope-power-systems> (accessed Feb. 15, 2021).
3. "Electromechanical Drilling in Dry Holes to Medium Depths," Ice Drilling Program. <https://icedrill.org/library/electromechanical-drilling-dry-holes-medium-depths> (accessed Feb. 10, 2021).
4. "Enhanced Multi-Mission Radioisotope Thermoelectric Generator (eMMRTG) Concept," NASA Radioisotope Power Systems. https://rps.nasa.gov/resources/56/enhanced-multi-mission-radioisotope-thermoelectric-generator-emmrtg-concept?category=fact_sheets (accessed Feb. 12, 2021).
5. June F. Zakrajsek et al. "Next-Generation Radioisotope Thermoelectric Generator Presentation," NASA Radioisotope Power Systems. August 2017. <https://rps.nasa.gov/resources/69/next-generation-radioisotope-thermoelectric-generator-presentation>
6. Adams et al "Multi-Functional Sandwich Composites for Spacecraft Applications: An Initial Assessment," NASA Technical Reports Server (NTRS). June 2007 <https://ntrs.nasa.gov/citations/20070022458>.
7. Bagshaw et al, "Novel wireless sensors for in situ measurement of sub-ice hydrologic systems," *Annals of Glaciology*, vol. 55, no. 65, pp. 41–50, ed 2014, doi: [10.3189/2014AoG65A007](https://doi.org/10.3189/2014AoG65A007).
8. Bagshaw et al, "Prototype wireless sensors for monitoring subsurface processes in snow and firn," *Journal of Glaciology*, vol. 64, no. 248, pp. 887–896, Dec. 2018, doi: [10.1017/jog.2018.76](https://doi.org/10.1017/jog.2018.76).
9. Bolotin, D. Hunter, D. Sheldon, Y. He, and D. Foor, "Compact Low Power Avionics for the Europa Lander Concept and Other Missions to Ocean Worlds," p. 11.
10. Bowen, L. Whitcomb, D. R. Yoerger, and R. McCabe, "Systems and methods for tethering underwater vehicles," US7621229B2, Nov. 24, 2009.
11. Calle, Luz M. "Corrosion on Mars: Effect of the Mars Environment on Spacecraft Materials". NASA Technical Reports Server (NTRS). June 2019 <https://ntrs.nasa.gov/citations/20190027256>
12. E. Schmidt, F. Bryson et al, "Vertical Entry Robot for Navigating Europa (VERNE): An ice- and ocean-profiling thermomechanical subsurface mission to search for life on Europa," submitted to *The Planetary Science Journal*, 2021.
13. Finless RTG Power System Concept. NASA. www.nasa.gov
14. H. Barnard et al, "The Coastal Autonomous Profiling and Boundary Layer System (CAPABLE)," in OCEANS 2010 MTS/IEEE SEATTLE, Sep. 2010, pp. 1–7, doi: [10.1109/OCEANS.2010.5664447](https://doi.org/10.1109/OCEANS.2010.5664447).
15. J. D. Lawrence, A. D. Mullen et al, "Subsurface Science and Search for Life in Ocean Worlds," submitted to *The Planetary Science Journal*, 2021.
16. J. F. Zakrajsek, "Update on RPS and Fuel Production OPAG," p. 12. April 23 2019.
17. J. Hong, P. Talalay, M. Sysoev, and X. Fan, "DEM modeling of ice cuttings transportation by electromechanical auger core drills," *Annals of Glaciology*, vol. 55, no. 68, pp. 65–71, ed 2014, doi: [10.3189/2014AoG68A002](https://doi.org/10.3189/2014AoG68A002).

18. J. Kowalski et al, "Navigation technology for exploration of glacier ice with maneuverable melting probes," *Cold Regions Science and Technology*, vol. 123, pp. 53–70, Mar. 2016, doi: [10.1016/j.coldregions.2015.11.006](https://doi.org/10.1016/j.coldregions.2015.11.006).
19. J. Mastropietro et al, "Design and preliminary thermal performance of the Mars Science Laboratory Rover heat exchangers," Jul. 2010, Accessed: Mar. 02, 2021. (Online). Available: <https://trs.jpl.nasa.gov/handle/2014/45114>.
20. Jakob Schwander, Heinrich Rufli, "Electromechanical Drilling in Dry Holes to Medium Depths," Ice Drilling Program. Ice Core Drilling. Proceedings of the Third International Workshop on Ice Drilling Technology (eds C. Rado and D. Beaudoin), 1988 pp. 32-37
21. K. W. Nicholls, H. F. J. Corr, C. L. Stewart, L. B. Lok, P. V. Brennan, and D. G. Vaughan, "A ground-based radar for measuring vertical strain rates and time-varying basal melt rates in ice sheets and shelves," *Journal of Glaciology*, vol. 61, no. 230, pp. 1079–1087, ed 2015, doi: [10.3189/2015JoG15J073](https://doi.org/10.3189/2015JoG15J073).
22. K. Zacny et al, "SLUSH: Europa hybrid deep drill," in 2018 IEEE Aerospace Conference, Mar. 2018, pp. 1–14, doi: [10.1109/AERO.2018.8396596](https://doi.org/10.1109/AERO.2018.8396596).
23. K. Zacny et al., "SLUSH: Search for Life Using Submersible Heated drill," presented at the 2019 Astrobiology Science Conference, Jun. 2019, Accessed: Feb. 11, 2021. [Online]. Available: <https://agu.confex.com/agu/abscon19/meetingapp.cgi/Paper/481905>.
24. Kohshima S., Shiraiwa T., Godoi M. A., Kubota K., Takeuchi N., and Shinbori K., "Ice core drilling on Southern Patagonia Icefield -Development of a new portable drill and the field expedition in 1999-," vol. 56, pp. 49–58, Mar. 2002.
25. Kroes, L. Venema, and R. Navarro, "Opto-mechanical design for transmission optics in cryogenic space instrumentation," in International Conference on Space Optics — ICSO 2012, Nov. 2017, vol. 10564, p. 1056426, doi: [10.1117/12.2309211](https://doi.org/10.1117/12.2309211).
26. L. S. Weinstock et al, "The Autonomous Pinger Unit of the Acoustic Navigation Network in EnEx-RANGE: an autonomous in-ice melting probe with acoustic instrumentation," *Annals of Glaciology*, pp. 1–10, undefined/ed, doi: [10.1017/aog.2020.67](https://doi.org/10.1017/aog.2020.67).
27. Lishman *et al.*, "Assessing the utility of acoustic communication for wireless sensors deployed beneath ice sheets," *Annals of Glaciology*, vol. 54, no. 64, pp. 124–134, ed 2013, doi: [10.3189/2013AoG64A022](https://doi.org/10.3189/2013AoG64A022).
28. Lu and S. Pilla, "Design and Fatigue Life Comparison of Steel and Composite Leaf Spring (2012-01-0944)," in Design of Automotive Composites, SAE, 2014, pp. 65–70.
29. M. Meister et al., "Icefin: Redesign and 2017 Antarctic Field Deployment," Oct. 2018, pp. 1–5, doi: [10.1109/OCEANS.2018.8604725](https://doi.org/10.1109/OCEANS.2018.8604725).
30. M. C. Smart et al, "The Use of Low Temperature Lithium-Ion Batteries to Enable the NASA Insight Mission on Mars," Meet. Abstr., vol. MA2019-02, no. 57, p. 2464, Sep. 2019, doi: [10.1149/MA2019-02/57/2464](https://doi.org/10.1149/MA2019-02/57/2464).
31. M. V. Jakuba et al., "Teleoperation and robotics under ice: Implications for planetary exploration," in 2018 IEEE Aerospace Conference, Mar. 2018, pp. 1–14, doi: [10.1109/AERO.2018.8396587](https://doi.org/10.1109/AERO.2018.8396587).
32. M. Pignol, "COTS-based applications in space avionics," in 2010 Design, Automation Test in Europe Conference Exhibition (DATE 2010), Mar. 2010, pp. 1213–1219, doi: [10.1109/DATE.2010.5456992](https://doi.org/10.1109/DATE.2010.5456992).

33. M. Soner et al, "Design and Fatigue Life Comparison of Steel and Composite Leaf Spring," Apr. 2012, pp. 2012-01–0944, doi: [10.4271/2012-01-0944](https://doi.org/10.4271/2012-01-0944).
34. Meyer *et al.*, "Attenuation of sound in glacier ice from 2 to 35 kHz," *The Cryosphere*, vol. 13, no. 4, pp. 1381–1394, Apr. 2019, doi: [10.5194/tc-13-1381-2019](https://doi.org/10.5194/tc-13-1381-2019).
35. O. Pradhan and A. J. Gasiewski, "Log periodic folded slot array antenna for an autonomous cryobot synthetic aperture radar for subsurface exploration of Europa," in 2016 IEEE International Symposium on Antennas and Propagation (APSURSI), Jun. 2016, pp. 2049–2050, doi: [10.1109/APS.2016.7696731](https://doi.org/10.1109/APS.2016.7696731).
36. P. Bhandari et al., "Performance Of The Mechanically Pumped Fluid Loop Rover Heat Rejection System Used For Thermal Control Of The Mars Science Laboratory Curiosity Rover On The Surface Of Mars," in 43rd International Conference on Environmental Systems, American Institute of Aeronautics and Astronautics.
37. P. Weiss, K. L. Yung, N. Kömle, S. M. Ko, E. Kaufmann, and G. Kargl, "Thermal drill sampling system onboard high-velocity impactors for exploring the subsurface of Europa," *Advances in Space Research*, vol. 48, no. 4, pp. 743–754, Aug. 2011, doi: [10.1016/j.asr.2010.01.015](https://doi.org/10.1016/j.asr.2010.01.015).
38. P. Weiss, K. L. Yung, T. C. Ng, N. Kömle, G. Kargl, and E. Kaufmann, "Study of a thermal drill head for the exploration of subsurface planetary ice layers," *Planetary and Space Science*, vol. 56, no. 9, pp. 1280–1292, Jul. 2008, doi: [10.1016/j.pss.2008.04.004](https://doi.org/10.1016/j.pss.2008.04.004).
39. P. Talalay et al, "Anti-torque systems of electromechanical cable-suspended drills and test results," *Annals of Glaciology*, vol. 55, no. 68, pp. 207–218, ed 2014, doi: [10.3189/2014AoG68A025](https://doi.org/10.3189/2014AoG68A025).
40. P. Weiss , K.L. Yung, N. Kömle, S.M. Ko , G. Kargl , E. Kaufmann, "A thermal drill head for the exploration of subsurface ice layers on Europa," International Workshop for Europa Lander: Science Goals and Experiments, Moscow Russia, February 2009
41. R. D. Christ and R. L. Wernli, "Chapter 9 - LARS and TMS," in *The ROV Manual (Second Edition)*, R. D. Christ and R. L. Wernli, Eds. Oxford: Butterworth-Heinemann, 2014, pp. 221–248.
42. R. Surampudi, "Energy Storage Technologies for Future Planetary Science Missions," JPL D-101146., Dec. 2017. Accessed: Nov. 04, 2020. (Online). Available: <https://solarsystem.nasa.gov/resources/549/energy-storage-technologies-for-future-planetary-science-missions>.
43. RPS Orbital and Surface Power - Radioisotope Thermoelectric Generator – eMMRTG. NASA Glenn Research Center. May 2017 <https://www1.grc.nasa.gov/wp-content/uploads/RPS-Orbital-and-Surface-Power-Radioisotope-Thermoelectric-Generator-eMMRTG.pdf>
44. S. C. Riser, D. Swift, and R. Drucker, "Profiling Floats in SOCCOM: Technical Capabilities for Studying the Southern Ocean," *Journal of Geophysical Research: Oceans*, vol. 123, no. 6, pp. 4055–4073, 2018, doi: <https://doi.org/10.1002/2017JC013419>.
45. S. Oleson, J. M. Newman, A. Dombard, and D. Meyer-Dombard, "Compass Final Report: Europa Tunnelbot," p. 70, 2019.
46. S. R. Matthes, D. F. Woerner, T. Caillat, and S. Pinkowski, "A Status Update on the eMMRTG Project," in 2019 IEEE Aerospace Conference, Mar. 2019, pp. 1–9, doi: [10.1109/AERO.2019.8741919](https://doi.org/10.1109/AERO.2019.8741919).
47. S. Shrestha and B. D. Dunn, "18 - Plasma electrolytic oxidation and anodising of aluminium alloys for spacecraft applications," in *Surface Engineering of Light Alloys*, H. Dong, Ed. Woodhead Publishing, 2010, pp. 603–641.

48. Scambos, Ted, "Compilation of ice temperature measurements at 10 m depth from international traverses 1957-1996." U.S. Antarctic Program (USAP) Data Center, 2020, doi: [10.15784/601325](https://doi.org/10.15784/601325).
49. Schmidt, B., Blankenship, D., Patterson, G. et al. "Active formation of 'chaos terrain' over shallow subsurface water on Europa," *Nature* 479, 502–505 (2011).
<https://doi.org/10.1038/nature10608>
50. Spears et al, "Under Ice in Antarctica: The Icefin Unmanned Underwater Vehicle Development and Deployment," *IEEE Robotics Automation Magazine*, vol. 23, no. 4, pp. 30–41, Dec. 2016, doi: [10.1109/MRA.2016.2578858](https://doi.org/10.1109/MRA.2016.2578858).
51. T. Benson et al., "IceCube Enhanced Hot Water Drill functional description," *Annals of Glaciology*, vol. 55, no. 68, pp. 105–114, ed 2014, doi: 10.3189/2014AoG68A032.
52. T. Brown, A. Stefanini, J. Sawoniewicz, I. Nesnas, and N. Georgiev, "Series Elastic Tether Management for Rappelling Rovers," in 2018 IEEE/RSJ International Conference on Intelligent Robots and Systems (IROS), Oct. 2018, pp. 2893–2900, doi: [10.1109/IROS.2018.8594134](https://doi.org/10.1109/IROS.2018.8594134).
53. T. Cwik et al, "A Technology Architecture for Accessing the Oceans of Icy Worlds," Oct. 2018, Accessed: Feb. 24, 2021. (Online). Available: <https://trs.jpl.nasa.gov/handle/2014/48794>.
54. U.S. Ice Drilling Program (2019) [Eclipse Drill Operations and Maintenance Manual](#). 1-69.
55. W. C. Stone, B. Hogan, V. Siegel, S. Lelievre, and C. Flesher, "Progress towards an optically powered cryobot," *Annals of Glaciology*, vol. 55, no. 65, pp. 2–13, ed 2014, doi: 10.3189/2014AoG65A200.
56. W. Stone et al., "Project VALKYRIE: Laser-Powered Cryobots and Other Methods for Penetrating Deep Ice on Ocean Worlds," in *Outer Solar System: Prospective Energy and Material Resources*, V. Badescu and K. Zacny, Eds. Cham: Springer International Publishing, 2018, pp. 47–165.
57. Y. Abdou *et al.*, "Design and performance of the South Pole Acoustic Test Setup," *Nuclear Instruments and Methods in Physics Research Section A: Accelerators, Spectrometers, Detectors and Associated Equipment*, vol. 683, pp. 78–90, Aug. 2012, doi: [10.1016/j.nima.2012.03.027](https://doi.org/10.1016/j.nima.2012.03.027).

X. Appendix

Table A1. Survey of life detection-relevant measurement and sampling technology (Lawrence et al 2021).

Context Imaging			
Setting	Technique	Relevant Examples	Qualitative Description
Planetary	Context Imager	MAHLI, MSL (Edgett et al., 2012); CLUPI, ExoMars (Josset et al., 2017)	High resolution imaging, auto focusing and focal stacking
	Context Imager, Co-Sighted with Spectrometer	SHERLOC, Mars 2020 (Beegle et al. 2015); PIXL, Mars 2020 (Allwood et al., 2015)	High resolution imaging co-sighted with scanning spectroscopy for chemical analysis
	Context Imager, Hyperspectral	MicrOmega/IR, ExoMars (Bibring et al., 2017); CIVA-M, Rosetta (Bibring et al., 2007)	Hyperspectral imaging for chemical analysis, coupled with microscopy
Ocean	Context Imagers	Underwater Imaging Review (J. S. Jaffe, 2014)	Diverse underwater imaging technologies
	Fluorescence Imagers	PLIF (Franks & Jaffe, 2008), (J. Jaffe et al., 2013)	Laser based techniques to detect and study planktonic life
	Hyperspectral Imagers	Underwater Hyperspectral Review (Liu et al., 2020);	Spectral techniques for studying seafloor life and geology
Glacier	Optical Televiewing	(Hubbard et al., 2008)	Map glacial boreholes, characterize materials in ice
Prototype	Europa Lander Prototypes	ELSSIE (Murchie et al., 2020); C-LIFE (Cook et al., 2020)	Multispectral imaging; Polarized imaging to detect chirality
Deep UV (DUV) Spectroscopy			
Planetary	Scanning DUV Spectroscopy	SHERLOC, Mars 2020 (Beegle et al. 2015)	Fluorescence & Raman with integrated context imaging
Ocean	DUV Fluorescence	DEBI-t (Salas et al. 2015)	Detection of microbes and organics in deep sea borehole
Glacier	Scanning DUV Fluorescence	WATSON (Eshelman et al. 2019, Malaska et al. 2020)	Mapping of organics and microbes in glacial borehole
Prototype	Flow Cytometry	UV Fluorescence Flow Cytometry (J. Lambert et al., 2010)	Sorting biogenic particles based on native UV fluorescence
Lab	DUV Fluorescence	(R. Bhartia et al., 2010)	Detection of microbes based on native DUV fluorescence
Ion Selective Electrodes (ISEs)			
<p><i>Electrochemistry for life detection is discussed by Thomson et al. (2019). Environmental ISEs reviewed by De Marco et al. (2007). Ocean microsensors reviewed by Crespo (2017); Kühl and Revsbech (2001)</i></p>			
Planetary	Hydrogel ISE	MECA-WCL, Phoenix (Kounaves et al. 2009, Hecht et al. 2009, Kounaves et al. 2010)	Wet chemistry analysis of Martian surface, discovery of perchlorates
Ocean	High Pressure SC-ISE	High Pressure SC-ISE (Weber et al. 2017)	Submersible SC-ISE tested under pressure
	Other Chemical Microsensors	Kühl & Revsbech 2001	Additional microsensors with ocean heritage
Ocean	ISFET	Biogeochemical-Argo (BGC-Argo) (Claustre et al. 2020)	Autonomous biogeochemical global ocean profiling floats

Glaciology	ISFET	Bagshaw et al. 2021	pH measurements in glacial meltwaters
Prototype	Microfluidic SC-ISE	MICA (Noell et al 2019); SPLICE (Chinn et al., 2017)	Microfluidic implementation and advancement of WCL capabilities
	Miniature SC-ISE	Miniature SC-ISE (Jamarillo & Noell 2020)	Description and characterization of miniaturized SC-ISEs
Microscope for Life Detection			
<i>Planetary microscopes review by J. L. Nadeau et al. (2018). Ocean microscopes review by Lombard et al. (2019) and Spanbauer et al. (2020) and ocean holography reviewed by Nayak et al. (2021).</i>			
Planetary (Geological Investigation)	Optical Microscope	MECA-OM, Phoenix (Hecht et al., 2008); Beagle 2 (Thomas et al., 2004); CIVA-M, Rosetta (Bibring et al. 2007); MicrOmega/Vis, ExoMars (Leroi et al. 2009);	Microscopic imaging for geologic studies, multiwavelength illumination, max resolution of several microns (~4 μm/pixel)
	Atomic Force Microscope	MECA-AFM, Phoenix (Hecht et al. 2008); MIDAS, Rosetta (Riedler et al. 2006)	Mechanical scanning at extremely high resolutions (<10 μm), slow sampling speeds
Ocean (Plankton Imaging)	Digital Holographic Microscope	In-Line (Bochdansky et al., 2013), (Jericho et al., 2010); Twin Beam Off Axis (Mullen et al 2019)	Volumetric imaging of plankton, near micron resolution, deep sea deployments
	Bright and Dark Field Imaging	Scripps Plankton Camera (Orenstein et al., 2020); Benthic Underwater Microscope (Mullen et al 2016)	Imaging of undisturbed plankton and seafloor specimen, near micron resolution, fluorescence imaging and focal stacking
	Imaging Flow Cytometry	Imaging FlowCytobot (Olson & Sosik 2007)	High throughput plankton imaging, long duration deployments
	Atomic Force Microscope	(Nishida et al., 2016)	Deep sea implementation of AFM
Field Tested (Life Detection)	Digital Holographic Microscope	Twin Beam Off Axis (Wallace et al., 2015), (Lindensmith et al., 2016); Lensless (Serabyn et al., 2018); Cytometry (Gracs et al., 2018)	Volumetric imaging of microbes, motility tracking, submicron resolution
	Fluorescence Light Field Microscope	ELVIS (T. Kim et al., 2020)	Coupled volumetric light field fluorescence imaging and holographic microscopy
Prototype (Life Detection)	Fourier Ptychography	Portable Ptychographic Microscope (Nguyen et al., 2020)	Computational imaging, large field of view, submicron resolution
	Multi-Spectral / Fluorescence	Europa Luminescence Microscope (Quinn et al., 2019)	Fluorescence using chemical stains, cubesat heritage
	Atomic Force Microscope	ANTONIE (Murray et al., 2019)	AFM integrated with optical microscope, designed for life detection
Raman Spectroscopy			
<i>Potential astrobology applications of Raman Spectroscopy discussed by Foucher (2019). Ocean Raman spectroscopy review by Du et al. 2020 and Brewer & Kirkwood 2013.</i>			
Planetary	UV Resonance Raman	SHERLOC, Mars 2020 (Beegle et al. 2015)	Scanning UV spectroscopy with integrated context imaging
	Standoff Raman	SuperCam, Mars 2020 (Perez et al., 2017)	Standoff Raman integrated with multiple types of spectroscopy
	Raman Spectroscopy	RLS, ExoMars (Rull et al., 2017)	Component of package for analysis of crushed rock samples

Ocean	Raman Spectroscopy	DORRIS (P. G. Brewer et al., 2004); RiP (X. Zhang et al., 2017)	In situ geochemistry of hydrothermal vent fluids, cold seeps fluids, and seafloor minerals, including deep sea operations
Lab	UV Resonance Raman	(Sapers et al., 2019); (N. Tarcea et al., 2007)	Investigations of UV Raman for life detection applications
	Single Cell Raman	Single Cell Analysis (Harz et al., 2009; Serrano et al., 2014) Flow Cytometry (Zhang et al. 2017, (Suzuki et al., 2019))	Raman analysis of single cells using advanced lab techniques, including rapid flow cytometry analysis
Prototype	SSE Raman	CIRS (J. L. Lambert & Wang, 2019)	SSE separation of Raman & fluorescence, lightfield camera
	Raman & Holography	Takahashi et al. 2020	Integrated holographic and Raman for underwater applications
	Raman with Flow Cell	Thomson et al. 2017	Raman integrated with flow cell for life detection applications

Nanopore Sequencing & Genomics

Potential astrobiology applications of sequencing technology discussed by Rezzonico (2014) and Carr et al. (2017). Ocean genomic instruments and sampling review by McQuillan & Robidart (2016) and Spanbauer et al. 2020.

Space	Nanopore	Castro-Wallace et al. 2016	Sequencing aboard the International Space Station
Ocean	Informational Biopolymer Analysis	ESP (Scholin et al. 2017); IISA-Gene (Fukuba et al. 2011)	Autonomous underwater DNA probe and protein arrays as well as qPCR, preservation of samples for lab analysis
	Genomic Collection & Preservation	ESP G3 (Yamahara et al. 2020)	<i>In situ</i> seawater filtration and chemical preservation for lab analysis, applications aboard autonomous vehicles
Prototype	Nanopore	Martian life detection (SETG, Carr et al. 2019)	DNA extraction and sequencing suite for Mars
In Development	Solid State Nanopore	Planetary exploration (Bywaters et al. 2017, Carr et al. 2020)	Solid state nanopore sequencing instruments for long duration and deep space applications
	Nanopore	Low Earth orbit sequencing (Saboda et al. 2019)	CubeSat incubation, DNA extraction, and sequencing payload designed for low Earth orbit

Mass Spectrometry & Separations

Planetary science mass spectrometry review by Arevalo et al. (2019). Searching for chemical biosignatures on ocean worlds discussed by Willis et al. (2020). Microchip electrophoresis & capillary electrophoresis for astrobiology reviewed by P. A. Willis et al. (2015) and Mora et al. (2012). Ocean mass spectrometry review by Chua et al. (2016).

Planetary	GC/LD-Ion Trap MS	MOMA, ExoMars (Goesmann et al. 2017)	Analyze volatile and refractory organics in Martian sediment
	GC-Quadrupole MS	SAM, MSL (Mahaffy et al., 2012)	Analyze volatiles from Martian atmosphere or sediments
	GC - Quadrupole MS	NMS, Huygens (Niemann et al. 2002)	Analyze atmosphere of Titan
Ocean	GC-MS	(Matz & Kibelka, 2000)	Submerged implementation of GC-MS
	Cycloidal-MS	TETHYS (Camilli & Duryea, 2009)	Tracked underwater hydrocarbon plumes
	Q-MS	ISMS (Wankel et al., 2010)	Investigated hydrothermal vents and biogeochemical fluxes
Prototype (Targeting Ocean Worlds)	CE - MS/LIF/C4D	OCEANS (Willis et al. 2019, Creamer et al. 2020)	Analyze liquid samples, use multiple detection methods
	GC/LD - Ion Trap MS	EMILI (W. B. Brinckerhoff et al., 2018; William B Brinckerhoff et al., 2019)	Building on heritage from MOMA, targeting Europa

	LC-TOF-MS	OASIS (Getty et al. 2013)	Analyzing liquid samples, searching for biosignatures
	GCxGC-MS	MASPEX-ORCA (Blase et al., 2020)	Analyze semi-volatiles and chemically derivatized biomolecules
Field Tested	ME-LIF	Chemical Laptop (Mora et al. 2020)	Microchip electrophoresis tested in field
Prototype	CE-LIF	MOA (Stockton et al. 2010); MOAB (Mathies et al., 2017); Mora et. al. 2015, Creamer et al. 2017	Capillary electrophoresis laser induced fluorescence, microfluidic implementation, high sensitivity detection of amino acids

Fluidic Systems & Flow Control

Satellite fluidic systems for microbiology review by Zea et al. (2020). Oceanographic millifluidic / microfluidic sensor systems by Nightingale et. al. (2015), and Fukuba & Fuji (2020). Ocean sampling for genomics reviewed by Spanbauer et. al. (2020) and McQuillan & Robidart (2016).

Planetary	Dispense reagents and calibrants	Mars Viking Lander (Klein et. al. 1977); WCL, Phoenix (Kounaves et al. 2009 & 2010)	Dispense and stir small volumes of solution for analyzing Martian surface regolith
Space		Microbiology on Satellites, Review (Zea et al. 2020)	
Field Tested	Microfluidic and millifluidic packages for space and landed missions	Microchip Electrophoresis (Mora et al. 2020); Subcritical Water Extraction (Kehl et al., 2019)	Fluidic systems integrating manifolds, pumps, valves, and processing; capable of biological and chemical analyses; achieving miniaturized form factors
Prototype		OWLS/OCEAN (Willis et al. 2019, Creamer et al. 2020); MICA (Noell et al 2019); SPLice (Chinn et al. 2017); MOAB/EOA (Mathies et 2017); Mora et al. 2011	
Ocean	Low Pressure, Fluidic System in Sealed Housings	ESP Scholin et al. 2017); Lab-On-Chip (Beaton et al., 2012); Flow Cytometry (Olson & Sosik 2007)	Fluidic systems within pressure sealed housings, integrated with diverse sensors (genomic, chemical, imaging), including microfluidic Lab-On-Chip systems
	Pressure-Balanced, Water Collection & Filtration	Breier et al. 2012, (Okamura et al., 2013), Mullen et al. 2020	Fluidic system for water sampling and filtration, pumping components held in pressure-balanced oil-filled housing
	Pressure-Balanced, Chemical & Biological Sensors	IISA-Gene (Fukuba 2011); Nutrients (Thouron et al., 2003); CHEMINI (Vuillemin et al., 2009); SAMI (Lai et al., 2018)	Fluidic system for chemical and biological analyses, fluidics elements all in pressure-balanced oil-filled housing
Lab	High Pressure Microfluidics	Hjort 2015, Andersson 2018	High pressure microfluidics for HPLC and other applications

Particulate Concentration

Review of laboratory techniques for cell and particle sorting by Shields et al. (2015)

Ocean	In Situ Membrane Filtration	SUPR (Breier et al., 2012; Govindarajan et al., 2015); ESP 3G (Yamahara et al., 2019)	<i>In situ</i> seawater filtration (>0.2 µm) and fixation, on robotic vehicles, allows lab microscopic and genomic analysis
	In Situ Membrane Filtration & Sample Analysis	ESP (Scholin et al. 2017)	<i>In situ</i> seawater filtration (>0.2 µm) and genomic analysis (qPCR, DNA and protein probe arrays) within underwater 'lab in a can'
Lab	Tangential Flow Filtration	Petrusevski et al. 1995, Giovannoni et al. 1990, Benner et al. 1997	Shipboard TFF, concentration of microbes from seawater, concentration for DNA analyses, 0.1 µm filtering (10 µm prefilter)

Sorting Flow Cytometry	UV Fluorescence (J. Lambert et al., 2010), Flow Cytometry Review (Vembadi et al., 2019)	Techniques using sheath flow, optical measurements, and active sorting to select particles of interest from larger volume
------------------------	---	---